

INSTALLATION & OPERATION MANUAL



FOR MX7000®
LIGHT BAR

Patent Number
5,091,828
D326,621

Code 3, Inc., a subsidiary of
Public Safety Equipment, Inc.

CODE 3[®]
PUBLIC SAFETY EQUIPMENT, INC.

★ **MX 7000** [®] ★

DUAL LEVEL LIGHT BAR

Contents:

Introduction	2
Unpacking & Pre-Installation	3
Installation & Mounting	3
Hook-on Mounting	4
Permanent Mounting	5
Wiring Instructions	6-7
Options & Specifications	8-14
Maintenance	15-19
Parts List (Replacement Parts / Exploded View)	19-24
D-Tech Rotator	25-26
Trouble Shooting	27-28
Notes	29-31
Warranty	32

IMPORTANT: *Read all instructions and warnings before installing and using.*
INSTALLER: *This manual must be delivered to the end user of this equipment.*

Introduction

The MX 7000® Light Bar is a dual-level light bar that is less than 6" high, yet delivers unobstructed 360° warning and more signal power and versatility than any other light bar of its size.

The low profile and aerodynamic lines of the MX reduce air drag, which results in fuel savings and stability at high speeds. This light bar has a strong extruded internal frame, shock-resistant polycarbonate lenses, and warning signals that exceed SAE standards.

The MX is designed on a modular basis, which means that the light bar can be customized to meet any requirements.

Because of its dual-level design, the MX has room for an incredible number of these options: standard or high speed rotators, StingRay™ oscillating signals, an Oscilaser™ in the top deck, alley lights and intersection or Pursuit Lights in the lower corners, and up to 12 locations for special purpose stationary lights in the lower deck. While we do not recommend a light installed in every location, the design of the MX 7000 offers the ultimate flexibility in the location of warning and auxiliary lights.



WARNING!

The use of this or any warning device does not insure that all drivers can or will observe or react to an emergency warning signal. Never take the right-of-way for granted. It is your responsibility to be sure you can proceed safely before entering an intersection, driving against traffic, responding at a high rate of speed, or walking on or around traffic lanes.

The effectiveness of this warning device is highly dependent upon correct mounting and wiring. Read and follow the manufacturer's instructions before installing or using this device. The vehicle operator should insure daily that all features of the device operate correctly. In use, the vehicle operator should insure the projection of the warning signal is not blocked by vehicle components (i.e.: open trunks or compartment doors), people, vehicles, or other obstructions.

This equipment is intended for use by authorized personnel only. It is the user's responsibility to understand and obey all laws regarding emergency warning devices. The user should check all applicable city, state and federal laws and regulations.

Public Safety Equipment, Inc., assumes no liability for any loss resulting from the use of this warning device.

Proper installation is vital to the performance of this warning device and the safe operation of the emergency vehicle. It is important to recognize that the operator of the emergency vehicle is under psychological and physiological stress caused by the emergency situation. The warning device should be installed in such a manner as to: A) Not reduce the output performance of the system, B) Place the controls within convenient reach of the operator so that he can operate the system without losing eye contact with the roadway.

Emergency warning devices often require high electrical voltages and/or currents. Properly protect and use caution around live electrical connections. Grounding or shorting of electrical connections can cause high current arcing, which can cause personal injury and/or severe vehicle damage, including fire.

PROPER INSTALLATION COMBINED WITH OPERATOR TRAINING IN THE PROPER USE OF EMERGENCY WARNING DEVICES IS ESSENTIAL TO INSURE THE SAFETY OF EMERGENCY PERSONNEL AND THE PUBLIC.

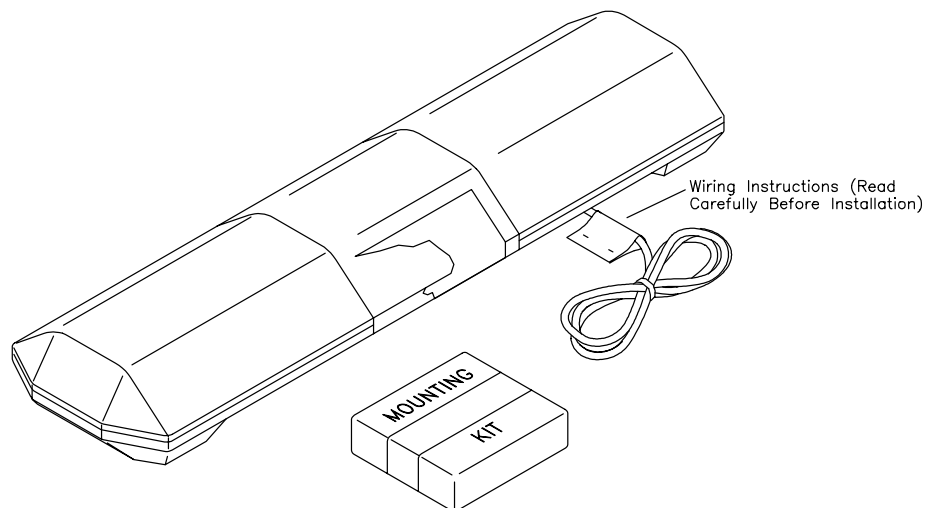

Unpacking & Pre-installation

Carefully remove the light bar and place it on a flat surface, taking care not to scratch the lenses or damage the cable coming out of the bottom. Examine the unit for transit damage, broken lamps, etc. Report any damage to the carrier and keep the shipping carton.

Standard light bars are built to operate on 12 volt D.C. negative ground (earth) vehicles. If you have an electrical system other than 12 volt D.C. negative ground (earth), and have not ordered a specially wired light bar, contact the factory for instructions.

Test the unit before installation. To test, touch the black wire to the ground (earth) and the other wires to +12 volts D.C., in accordance with the instructions attached to the cable (an automotive battery is preferable for this test). A battery charger may be used, but please note that some electronic options (flashers, stingrays, etc.) may not operate normally when powered by a battery charger. If problems occur at this point, contact the factory.

Installation & Mounting

WARNING!



Utilizing non-factory supplied screws and/or mounting brackets and/or the improper number of screws may result in loss of warranty coverage on the equipment.

MOUNTING HARDWARE-All mounting hardware is packed in a small box inside the main carton. Four standard kits are available:

(1) Hook-On Type, (1) Tow and Recovery and (2) Permanent Types. These are discussed in detail later. **Note:** Hook-on mounting for "gutterless" type vehicles will require a special hook for mounting. Several are available. Contact the factory for details.

SIREN SPEAKERS

(Single Speaker Installation in 43", 47", 52" & 58" Light bars) Speaker Installation is advised at this point while the speaker section is easily accessible. To install a speaker, first remove the two (2) hex-head screws, (4 screws on 58 1/4" bars) from the bottom of the perforated side of the speaker cover. The cover is hinged at the back--pull the front of the cover up and over the lenses to remove it. Figure 1 shows the speaker cover opened and location holes for installing a Code 3 "LP" speaker. If other than a Code 3 "LP" speaker is used, two possibilities exist for speaker installation. An "LPSPKR" conversion kit is available from the factory to mount an existing speaker in an MX7000™. Otherwise, holes must be drilled for installation. The center speaker deck is 1/8" thick aluminum and may be drilled almost anywhere. Before drilling, however, it is imperative to remove the speaker deck so as not to damage any components below. All holes in this area not used must be sealed with some type of water resistant caulking so that components below are protected from the elements. Re-install the speaker deck, then mount the speaker and connect the leads to the terminal block. Non "LP" speaker bells must be trimmed to match the speaker cover contour. Replace the cover.

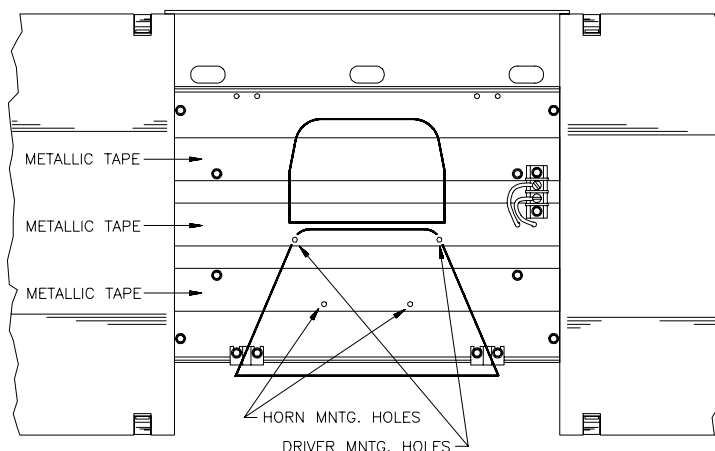

Figure 1

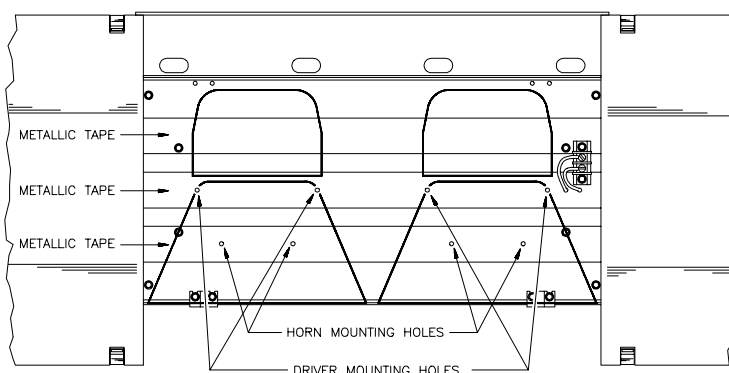

Figure 2

(Dual Speaker Installation in 52" & 58 1/4" Light bars) Using the same procedure as above, install the speakers using the mounting holes in Figure 2 (For a Code 3 "LP" speaker). When using the two speakers, follow the manufacturer's instructions for correct phasing of speakers.

Hook-on Mounting

Begin the installation by attaching the rubber feet to the mounting brackets using the black 1/4" carriage bolts and 1/4" nuts provided. See Figure 3 (Do not install shims at this time).

Place the light bar upside down on a table or other work surface, being careful not to scratch the lenses. Slide the 5/16" carriage bolts into the frame. Secure the mounting brackets finger tight so they support the weight of the light bar, but still are positionable. Locate the vehicle on a level surface.

Place the light bar on the roof of the vehicle. Place a soft pad in the center of the roof to protect the paint. The mounting brackets must be placed so that the rubber feet are resting on the curved section of the roof, see Figure 4. This is the strongest part of the roof. Once the light bar is centered, tighten the mounting bracket to the light bar.

Using a tape measure and a level, center the light bar from side to side and locate a position on the roof where the light bar is level.

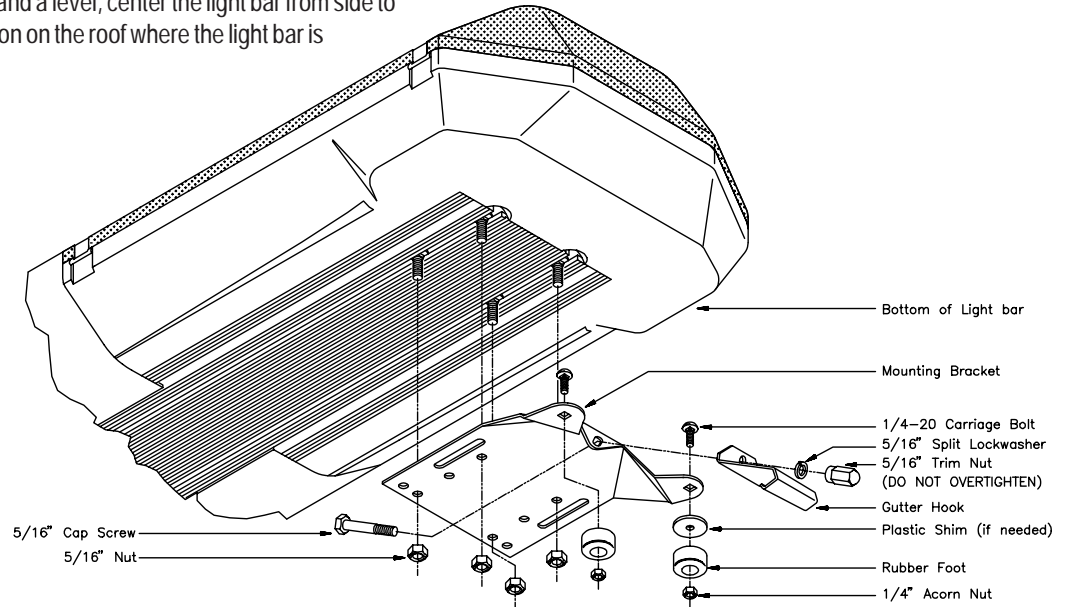

Figure 3

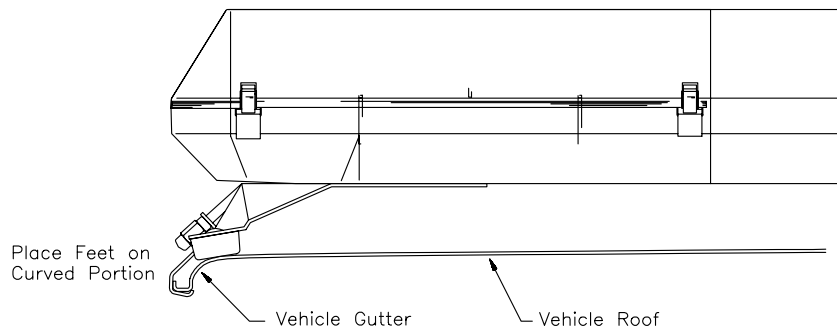

Figure 4

The shims provided may be used here to help level the light bar, see Figure 3. Also, the tabs on the mounting brackets may be bent at any angle to match the curvature of the roof.

Select the appropriate length cap screw and insert through the holes in the gutter hook and mounting bracket, and into a lockwasher and acorn nut as shown in Figure 3. If a special hook for a "gutterless" vehicle is used, refer to the instructions for that hook at this time. The stainless steel cap screws supplied are sized for the most common installations, but longer and shorter bolts are available at any hardware store.

Tighten the cap screws on both sides evenly keeping the light bar centered and level.

NOTE: Tighten only until the bar is secure (bar does not move when bumped sharply with the heel of the palm). It is NOT necessary to dimple the roof to obtain a stable attachment. If the light bar "bows" more than 3/16" (determined by placing a straightedge along the front, bottom part of the frame and measuring downward at the center of the frame), loosen the 5/16" trim nut slightly.

Re-Installation: When moving a light bar from one vehicle to another, we suggest that new rubber feet be used. These are standard hardware items, and can usually be found at any hardware store, or can be ordered from the factory.

The special hooks are stainless steel and should be saved and reused. Mounting kit parts are available to permit remounting on vehicles of different design or make. Consult your local dealer or *Code 3, Inc.* for detailed information.

Permanent Mounting

Typical Mounting: Refer to Figure 5. Place the light bar upside down on a table or other work surface, being careful not to scratch the lenses. Slide the 5/16" carriage bolts into the frame. Secure the mounting brackets finger tight so they support the weight of the light bar.

Place the unit on the roof of the vehicle. Place a soft pad in the center of the roof to protect the paint. The mounting brackets must be placed so that they are resting on the curved section of the roof, see Figure 6. This is the strongest part of the roof. Once the light bar is centered, tighten mounting brackets to light bar.

Using a tape measure and a level, center the light bar from side to side and locate a position of the roof where the light bar is level. The shims provided may be used here to help level the light bar. Also, the tabs on the mounting bracket may be bent at any angle to match the curvature of the roof (see Figure 6).

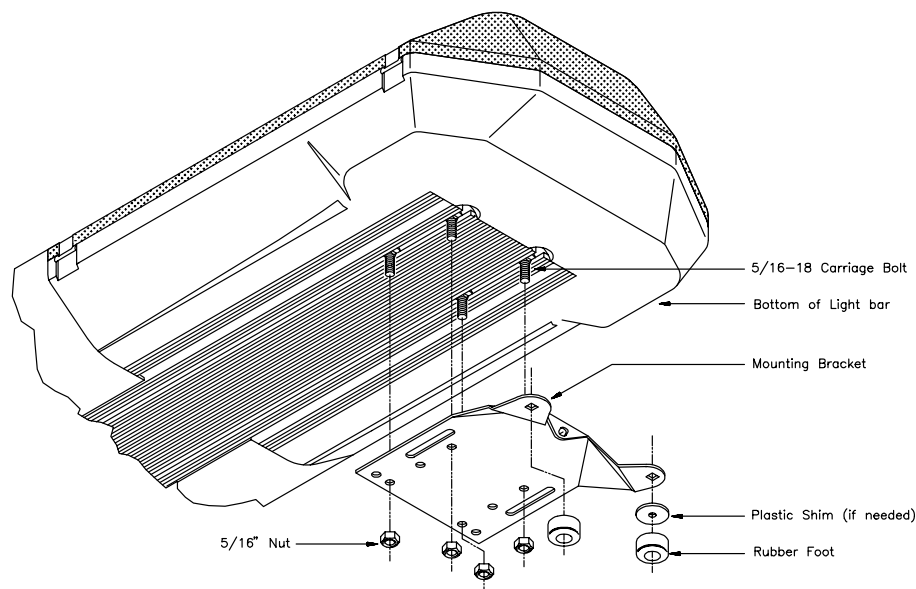

Figure 5

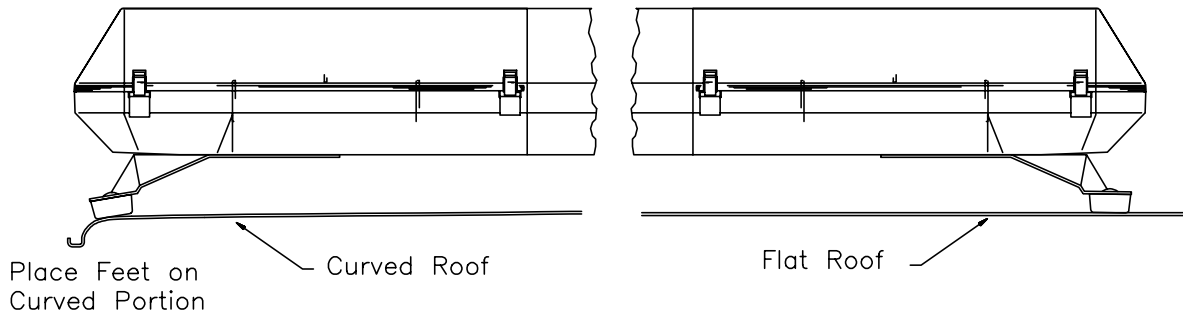

Figure 6

Once the light bar is level and centered, mark the holes through the mounting tabs and remove the light bar from the vehicle. Make sure that the drill will not damage anything when penetrating the roof. Drill the mounting holes and remove any burrs. Attachment can be made using 1/4" cap screws, toggle bolts, or other fasteners as may be convenient. Use sealant as necessary to prevent water leakage into the vehicle.

Wiring Instructions



WARNING!

Larger wires and tight connections will provide longer service life for components. For high current wires it is highly recommended that terminal blocks or soldered connections be used with shrink tubing to protect the connections. Do not use insulation displacement connectors (e.g. 3M® Scotchlock type connectors). Route wiring using grommets and sealant when passing through compartment walls. Minimize the number of splices to reduce voltage drop. High ambient temperatures (e.g. underhood) will significantly reduce the current carrying capacity of wires, fuses, and circuit breakers. Use "SXL" type wire in engine compartment. All wiring should conform to the minimum wire size and other recommendations of the manufacturer and be protected from moving parts and hot surfaces. Looms, grommets, cable ties, and similar installation hardware should be used to anchor and protect all wiring. Fuses or circuit breakers should be located as close to the power takeoff points as possible and properly sized to protect the wiring and devices. Particular attention should be paid to the location and method of making electrical connections and splices to protect these points from corrosion and loss of conductivity.

Ground terminations should only be made to substantial chassis components, preferably directly to the vehicle battery. The user should install a fuse sized to approximately 125% of the maximum Amp capacity in the supply line to protect against short circuits. For example, a 30 Amp fuse should carry a maximum of 24 Amps. **DO NOT USE 1/4" DIAMETER GLASS FUSES AS THEY ARE NOT SUITABLE FOR CONTINUOUS DUTY IN SIZES ABOVE 15 AMPS.** Circuit breakers are very sensitive to high temperatures and will "false trip" when mounted in hot environments or operated close to their capacity.

Before attempting to connect wiring refer to wire tag attached to the lightbar's main cable. Each wire in the cable controls a separate lightbar function as described in the wire tag.

The only significant difference between the MX 7000® with optional ArrowStik® and a conventional MX 7000, is the additional, thinner cable exiting the bottom of the lightbar. The larger cable is the lightbar power cable. Route the wiring cable into the engine or passenger compartment, taking care to use grommets and to apply sealant around openings to keep water out. It is advisable to leave an extra loop of cable when installing the light bar to allow for future changes or reinstallations. Connect the black lead to a solid frame ground (earth), preferably, the (-) or ground (earth) side of the battery and bring the other wires to the control heads or switches. Connect the wires as directed by the wiring instructions on the cable.

Arrowstik® / Narrowstik®

OPTIONAL HALOGEN ARROWSTIK® (7-wire) / L.E.D. NARROWSTIK® (11-wire) WIRING AND CONTROL HEAD INSTALLATION - After installation of the lightbar, route the smaller of the two power cables through the vehicle to the location chosen for the control head. Cut the cable to length and strip back the outer insulation to expose the seven or eleven colored wires. Strip back 1/8" - 1/4" of colored insulation from each of the wires in the cable. Connect these wires to the seven position / eleven position terminal plug enclosed in the user parts bag, according to the diagram on the bottom of the control head.

- Refer to the control head manual packaged with the lightbar for control head installation and operation instruction.

Route the wiring cable into the engine or passenger compartment, taking care to use grommets and to apply sealant around openings to keep water out. It is advisable to leave an extra loop of cable when installing the light bar to allow for future changes or reinstallations. Connect the black lead to a solid frame ground (earth), preferably, the (-) or ground (earth) side of the battery and bring the other wires to the control head or switches. Connect the wires to the control head or switch (as directed by the wiring instructions on the cable). Next, calculate the light bar power draw. Table 1 consists of an equation and data for quick calculating of light bar load. Run a power wire from the control head to the (+) or positive side of the battery, the alternator, or to the stud on the battery side of the starter solenoid. Use Table 2 for reference.

Speaker Wires: If the light bar has a speaker section, the blue wires go to the siren amplifier and are to be connected in accordance with the siren manufacturer's instructions. Test the unit for proper operation. **Caution - Operating a siren with a live speaker can inflict hearing damage-- always use hearing protection.**

Table 2	
RECOMMENDED SWITCH CONTROL MINIMUM WIRE SIZES	
Based on 15-Foot Wire Run	
Amp Draw	Min. Wire Size
Below 8	#16 AWG
9-13	#14 AWG
14-21	#12 AWG
22-36	#10 AWG
37-56	#8 AWG

Table 1			
Total Watts in Light bar Divided by 12 Volts Equals Amperage Draw or:			
Watts / 12 Volts = Amp Draw			
Bulb Type	Location	Wattage	Amp Draw
1156	Stationary/ Flashing Lights	28	2.33
S795	Standard Rotating Lamps	50	4.17
	Alley Lights		
	Intersection Lights		
	Stationary/Flashing Lights		
H-1	Rotating Lamps	55	4.58
194	D.O.T. Lamps	3	.25
211-2	ArrowStik® 12	1	
573	ArrowStik	25	2.08

Options & Specifications

Many options are available for the MX 7000. This section is designed to describe the function of, and maintenance for, the various MX 7000 options.

STINGRAY™ - The StingRay is a modified rotator which produces a patented three-mode signal that (1) oscillates to the rear, (2) rotates conventionally, and (3) oscillates to the front. Lamp and reflector maintenance is the same as for a typical rotating lamp.

INTERSECTION LIGHTS - A high intensity 120° oscillator, located in the lower outboard corner of the light bar. Maintenance of these units is much the same as for a typical rotator. The lamps used here are the bayonet type. Two mounting screws hold the assembly in place. **Note:** Never install a black worm gear on the 120° Intersection Light.

PURSUIT LIGHTS - Same as intersections lights except sweep angle is only 70°.

ALLEY LIGHTS - Located in the lower section of the light bar at each end, to provide light to the side of the vehicle. The lamps used are a bayonet type and the unit is held down with 2 #8 X 5/8" screws. (An additional screw in a curved slot controls the aim of the alley light in light bars that **do not** incorporate an ArrowStik. Simply loosen this screw, adjust the aim and tighten. (This screw does not need to be loosened when the whole unit is removed.)

HIGH SPEED ROTATOR - A rotator that produces twice as many flashes as a conventional assembly. The only significant difference between this unit and a normal assembly is that a faster motor is used. Maintenance is the same as for a typical rotator.

STATIONARY LAMPS/TAKEDOWN LIGHTS - A stationary reflector assembly used for flashing, takedown, and/or work light applications. These are located in the lower section of the light bar. Lamps in these units are bayonet type and the units are mounted with two screws.

LED WARNING MODULES

L.E.D. Fusing Considerations

Although the average current draw per module is very low, due to the type of circuit used to power each module the instantaneous peak current to a module can be significantly higher during low voltage conditions. To avoid prematurely blowing ATO style fuses or tripping breakers it is recommended the following rule-of-thumb be used to size fuses or breakers. This is especially important in lightbars with many LED modules running off a single fused source wire,

Minimum fuse size calculation:

1.5 x (number of modules being fused)

Example:

MX700™ Lightbar with 2 corner modules (2 per module) and 4 directional modules.

Minimum fuse requirement for single fuse - $1.5(2+2+4) = 10A$ minimum

WARNING!



This Product contains high intensity LED devices. To prevent eye damage, DO NOT stare into light beam at close range.

Dim Operation

Lightbar LED modules are equipped with a low power "Dimming" mode as standard. Dimming will be controlled by applying +12V by way of the appropriate wire(color) in the wire harness/wire list. When DIM is engaged the LED's will operate in a reduced power mode.

For safety purposes, the corner modules in lightbars are not connected to the dimming circuit. This ensures that when corner modules are turned on, full 360 degree coverage and compliance with SAE warning light standards is provided.

The DIM control wires(two white wires) located on each of the modules are connected from one module to the next. To disable the dimming function on a particular module, disconnect the white wires. Then reconnect the white wire to the white wire on another module that has dimming enabled.



WARNING!

The Dim setting reduces the light output of emergency warning lights reducing the effectiveness of them especially in brightly lit areas. Failure to use adequate light for the circumstances can cause motorists to fail to see the emergency vehicle and lead to serious personal injury or death. Never use the DIM setting in a brightly lit area. Use of the DIM setting may cause emergency lights to not comply with applicable emergency warning light standards. Use caution when using the DIM setting to assure that motorists can clearly see the emergency vehicle.

Code 3® OPTIX™ 360 DEGREE CORNER MODULES

The MX7000® Lightbar may be equipped with Code 3® OPTIX™ 360 degree corner LED modules that provide a full 360 degree of warning. The optic has been designed to exceed all applicable requirements for 360 degree warning devices in Red, Blue, and Amber. The new OPTIX corner module is a (1" X 6") module and uses larger, higher efficiency, TIR optics to produce an enhanced corner signal over the existing (1" X 4") Code 3 LED X™ corner module. While the OPTIX will become the standard corner module for most configurations, the LED X corner module will still be available and may be required for some configurations. Installation and Operation for both modules will be the same. Consult the factory for further information.

Operating Specifications for 360 degree module:

Operating Voltage: 10-16 VDC, Reverse Polarity Protection

Current Draw : Red/Amber - .5A avg @ 12.8 Volts

Blue/White - .8A avg @ 12.8 Volts

Available Colors - Red, Blue, Amber and White

Master/Slave Operation

Each 360 degree corner module consists of a "master" and a "slave" driver circuit board, 360 degree optics and LED light engines along with a single integrated heatsink bracket.

The "master" circuit board (rear position) must always be powered for the "slave"(front position) to flash. The "master" is always located in the rear position of the module. The lightbar is wired to allow running only the rear facing LED on each module by removing power to the front facing "slave" module. This gives a "front-cutoff" function. The flash pattern for each corner pair can be selected by shorting together the 2-pin header J1, on the "master", momentarily and releasing. The module is set-up for "Cycleflash" as a standard. Holding down the 2-pin header for 5 sec., or longer, and releasing will return the pattern to Cycleflash. The following chart describes the available patterns and order;

360 Degree Module Flash Pattern - Table 3

See Figure 22

Flash Pattern	Description
Cycle Flash	Cycles through various patterns @ 70 fpm
Five Flash	Five Pulses per flash @ 70 fpm
Quad Flash	Four Pulses per flash @ 70 fpm
NFPA	Four Pulses, 70% Duty Cycle @ 75 fpm
Triple Flash	Three Pulses per flash @ 70 fpm
Quad Pop Flash	Four Pulses per flash (3 equal, 1 extended) @ 70 fpm

Both heads will be in the mode selected. Both heads will flash together unless in Front Cut-off mode.

LED DIRECTIONAL MODULES

In addition to the 360 warning modules the lightbar may be equipped with a number of single head directional warning LED modules. These modules are available in either the existing LED X™ (1" X 4") or the new Code 3® OPTIX™ (1" X 6") and LC-LED directional modules in stationary and flashing versions (see figure 8). The stationary versions can be flashed by connecting the module(s) to any flasher that does not require ground through the load (example: Code 3® 700 series relay flasher). The flashing modules will have "Cycleflash" as the standard pattern. The OPTIX and LEDX flash pattern can be changed by shorting the 2-pin header, J1 as shown in Figure 22, momentarily then releasing. Table 4 shows the available patterns and the order when stepping through patterns. The module can be reset to "Cycleflash" by shorting the header for greater than 5 sec. and releasing.

Operating Specifications for directional module:

Operating Voltage: 10-16 VDC, Reverse Polarity Protection

Current Draw : Flashing Module

Red/Amber - .25A avg @ 12.8 Volts

Blue/White - .4A avg @ 12.8 Volts

Steady Burn Module

Red/Amber - .5A avg @ 12.8 Volts

Blue/White - .8A avg @ 12.8 Volts

Available Colors - Red , Blue, Amber, and White

Directional module Flash Pattern - Table 2

Flash Pattern	Description
Cycle Flash	Cycles through various patterns @ 70 fpm
Steady-Burn	Steady-Burn
Five Flash	Five Pulses per flash @ 70 fpm
Quad Flash	Four Pulses per flash @ 70 fpm
Triple Flash	Three Pulses per flash @ 70 fpm
Double Flash	Two Pulses per flash @ 70 fpm
Fast Double Flash	Two Pulses per flash @ 85 fpm
NFPA	Four Pulses, 70% Duty Cycle @ 75 fpm
Quad Pop Flash	Four Pulses per flash (3 equal, 1 extended) @ 70 fpm
Triple Pop Flash	Three Pulses per flash (2 equal, 1 extended) @ 70 fpm
Double Pop Flash	Two Pulses per flash (1 equal, 1 extended) @ 70 fpm

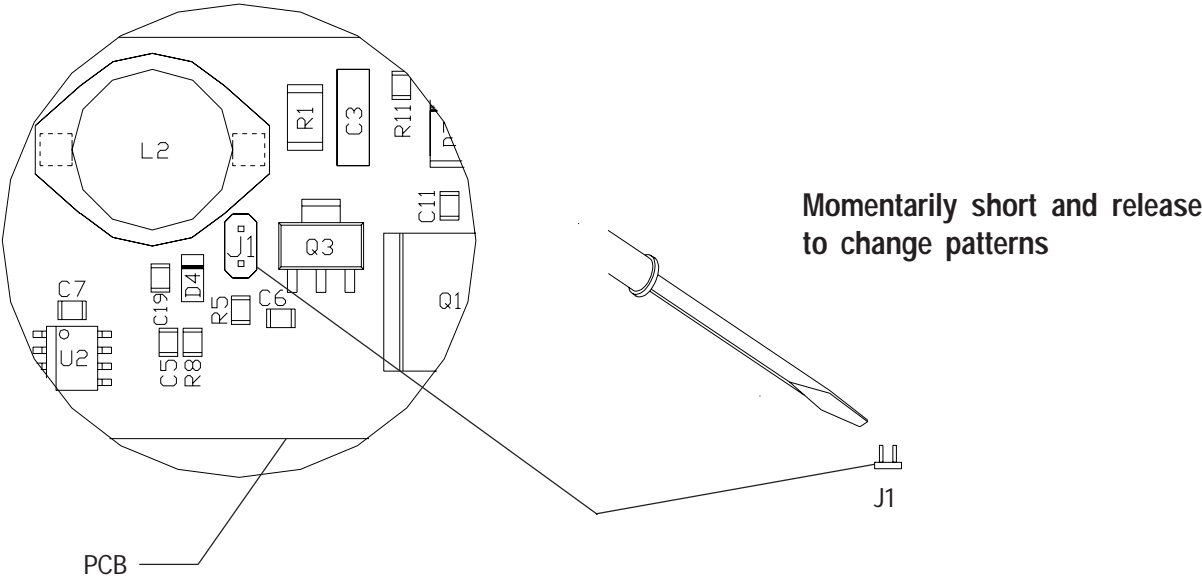

Flash Pattern Header for OPTIX/LEDX

FIGURE 22

STOP/TURN/TAIL LIGHTS - Located in the upper or lower section of the light bar facing rear, one on the driver side, one on the passenger side, these lights provide stop, turn and tail signals to following traffic when connected to the vehicle lighting system. Lamps used are an 1157 bayonet type.

D.O.T. LIGHTS - A set of three marker lights as required by the Department of Transportation for truck application. Lamps are wedge base '194' type.

FLASHER - Table 3 (below) shows the different models and their functions.

Features	360RS	360RD	360RDK	700	710/711
100W (2 lights), Alternating Flash	X			X	
200W (4 lights), Alternating Flash, Rear Only or Front & Rear		X	X		
200W (4 lights), Alternating Flash Rear Only, Front & Rear, or Steady Burn Front/Rear Flash			X		
200W Heavy Duty Alternating Flash				X	X
200W Heavy Duty Programmed Flash					X

STROBE LIGHTING CONNECTIONS

Flash Patterns - All power supplies offer "Quad Flash" and "Random Flash". The flash patterns are controlled by jumpers on the power supply and can be changed by first removing the power supply from the lightbar and then setting the jumpers. Refer to the following tables:

Jumper	Quad	Random
J9	2 - 3	1 - 2
J36	2 - 3	2 - 3

Jumper	Quad	Random
J31	2 - 3	1 - 2

	Quad	Random
YELLOW	N/C	+12

Rear Only Flash Pattern

Connect the RED and/or RED/BLK wire in the 16 wire cable to + 12 VDC through a user supplied switch.

4/6 Head: Rear inboard and outboard strobes on each side will flash at a minimum rate of 70 FPM (flashes per minute).

2 Head: If rear inboard strobes are present, strobes will flash at a minimum rate of 70 FPM.

Alternating Flash Pattern

Connect the RED and/or RED/BLK wire and the GREEN wire in the 16 wire cable to + 12 VDC through a user supplied switch. This mode overrides **REAR ONLY MODE**.

4/6 Head: Front and Rear inboard and outboard strobes on each side will flash at a minimum rate of 70 FPM.

2 Head: If rear inboard strobes are present, strobes will flash at a minimum rate of 70 FPM.

Pursuit Flash Pattern

Connect the RED and/or RED/BLK wire and the GRN/BLK wire in the 16 wire cable to +12 VDC through a user supplied switch. This mode overrides **ALL OTHER MODES**.

4/6 Head: Front inboard and outboard strobes on each side will flash at a minimum rate of 70 FPM.

2 Head: If front inboard strobes are present, strobe will flash at a minimum rate of 70 FPM.

OSCILASER™ - This is a highly effective warning light that features a constant 35 watt halogen signal that covers every area within it's field of illumination at least once per second. It has an up and down as well as a side to side signal. Maintenance for these units is much the same as a typical rotator. The lamps used are bayonet type. This unit is located in the upper center section and/or in the center position in the outboard sections of the light bar. See Figure 8.

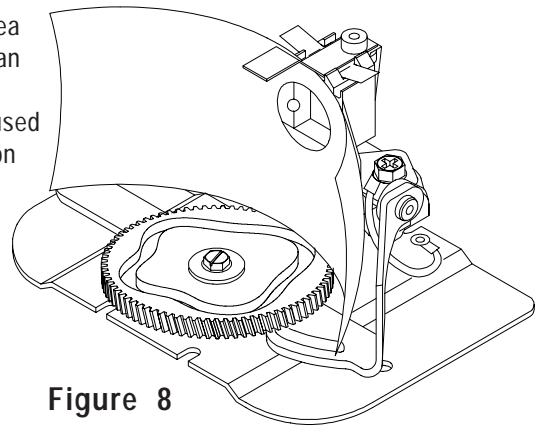

Figure 8

Multi-Functional Intersection Control System - This system allows multiple lighting options with a single pair of intersection lights. The control center of the system is the Multi-Functional Control Module located in the lower section of the light bar. This combined with the Sensing Lighthouse Assemblies, located in the front lower section, allows the operator to select (4) four modes of operation - intersection, driver side alley, passenger side alley and takedown positions.

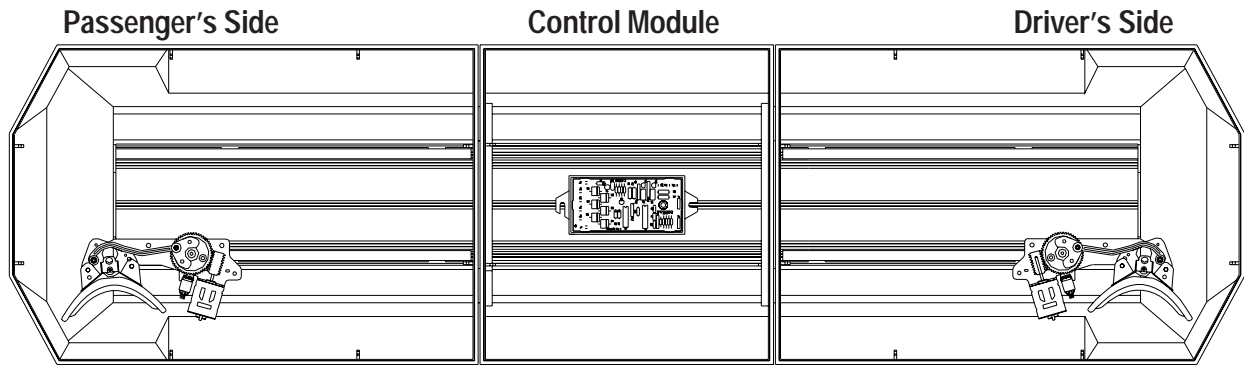

Figure 9

Sensing Lighthouse Assembly - As with the standard intersection lights, these are high intensity 120 degree oscillating light assemblies. With addition of the Position Sensing module these lights can be placed in the takedown or alley positions.

Note: If the gear assembly is replaced, care must be taken to insure that the flat nylon washer is seated between the gear and the bottom plate to prevent premature wear and failure.

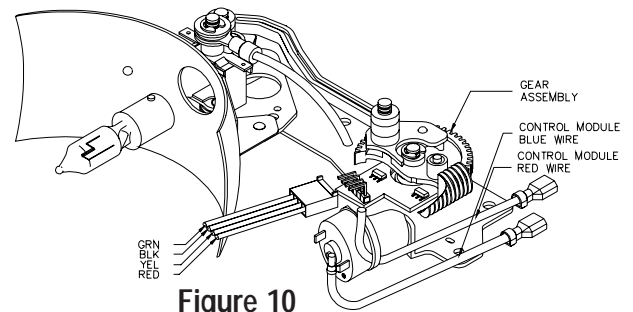
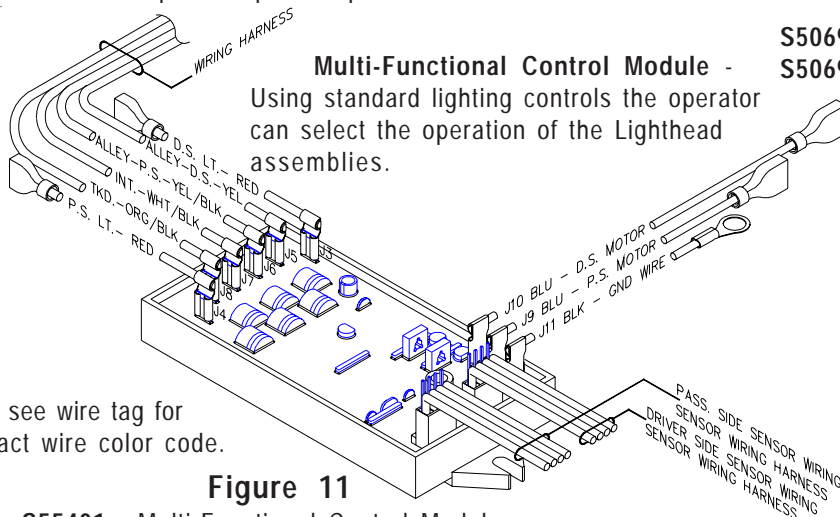

Figure 10

S50690 - Driver side assembly
S50691 - Passenger side assembly



Multi-Functional Control Module - Using standard lighting controls the operator can select the operation of the Lighthouse assemblies.

* - see wire tag for exact wire color code.

Figure 11

S55401 - Multi-Functional Control Module

Sensor Wiring Harness -
Red - Power
Blk - Ground
Grn - Alley
Yel - Takedown

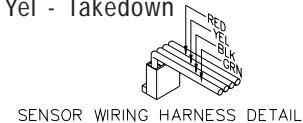

Figure 12

Operation: The Multi-Functional Intersection Control System will allow the user to obtain Takedown, Intersection and Alley functions with a single pair of intersection modules. The operation is as follows;

NOTE: Wiring Colors May Vary, Refer To Wire Tag For Exact Colors.

Passenger Side Alley - When the (YEL/BLK) wire is connected to a source of +12VDC the passenger's side intersection module will move to the alley position.

Driver Side Alley - When the (YEL) wire is connected to a source of +12VDC the driver's side intersection module will move to the alley position.

Intersection - When the (WHT/BLK) wire is connected to a source of +12VDC both intersection modules will oscillate. **When Intersection mode is selected the Passenger side and Driver side Alley mode will be overridden. The user cannot obtain Alley functions while in Intersection mode.**

Takedown - When the (ORG/BLK) wire is connected to a source of +12VDC both intersection modules will move to the takedown position. **When in Takedown mode, the Alley and Intersection modes are overridden.**

**NOTE: ALL DEVICES USED TO SWITCH +12VDC TO EACH CONTROL WIRE
MUST BE RATED FOR A MINIMUM OF 10A.**

Maintenance

Lens Cleaning

Use plain water and a soft cloth, or Code 3® lens polish and a very soft paper towel or facial tissue. Because plastic scratches easily, cleaning is recommended only when necessary (about every six months). Do not subject the lenses to car washes that use brushes, as these will scratch the lenses.

Lens Removal

First, if there is a speaker cover, remove it as outlined in the Pre-Installation Section of this manual. Next, disengage the lens clips (4 per lens) as shown in Figure 13. Finally, insert a screwdriver into the inside edge or corner of the lens, see Figure 13, and twist the screwdriver to lift the lens.

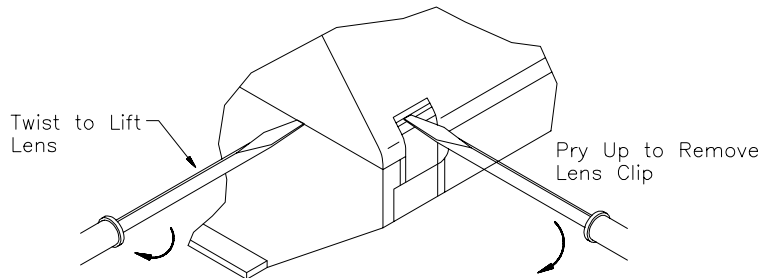

Figure 13

Changing Rotating Reflector Lamps

WARNING!



Lamps are extremely hot! Allow to cool completely before attempting to remove. Gloves and eye protection should be worn when handling halogen lamps as they are pressurized and accidental breakage can result in flying glass.

Remove the lens as outlined above. Next, inspect the lamp and compare to Figure 14 to determine lamp type. It may be necessary to remove any rotating or cylindrical filters to make access easier. Note: Make sure lamp is cool before attempting to change it. Also, when installing a new lamp, be sure not to touch the glass with fingers. If contact is made, clean the glass with a soft cloth after inspection.

H-1: First grasp lamp at base and turn until retaining clip tab is accessible. Using a blade screwdriver, remove retaining clip and pull lamp straight up. Replace with new lamp. Insure that the power lead and retaining clip is fully seated.

S-795 (Bayonet Style): Push down and turn to remove lamp. Install a new lamp the same way.

Note: If attempting to clean the reflector, use only a mild glass cleaner and a very soft cloth. Do not attempt to use any wax type products as these will burn onto the reflector.

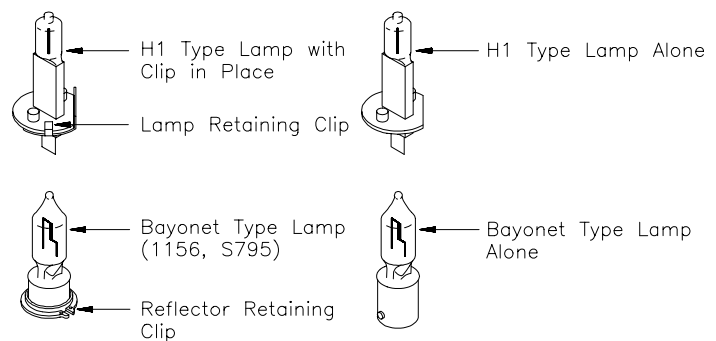

Figure 14

Changing Lower Unit Lamp and/or Filter

Refer to Figure 16. Remove closeout plate by lifting front of plate and sliding tabs out of midplate to expose components below. In most cases, these lamps will be a bayonet style, so simply push in and turn counterclockwise to remove. Lower filters can be taken out by removing mounting screw and sliding filter past reflector while tilting reflector back slightly. Refer to Figure 15. All lights have a special "J" slot socket that keeps the lamp filament horizontal. Insert the replacement lamp with a socket pin in the 11 o'clock position then push in and turn clockwise until the filament is horizontal.

Maintenance for Upper and Lower Level Components (including Flasher and Stingray Electronics)

Upper level components may be replaced by removing the appropriate fasteners attaching the components as shown in Figure 19. Carefully pull the electrical leads up through the access hole in the midplate and disconnect at the quickslide terminal. The midplate assembly can be removed entirely from the light bar in Steps 1 and 2 below and serviced at a workbench. Reassemble as explained in Step 5.

To replace a lower level component, follow these steps:

- 1.) Remove the Closeout plates by lifting the outer edge and sliding the tabs out of the midplate.
- 2.) Remove four 8-32 X 3/8" screws to detach the midplate (see Figure 15, the rotating reflector may be moved for better access by turning the drive worm with thumb or forefinger.) Remove the midplate by disconnecting the rotator electrical leads at their quick slide terminals.
- 3.) It is important that all lower level components are attached with fasteners that extend through the locator strip and into the frame. Use #8 X 1/2" S.S. sheet metal screws for stationary reflectors and #8 X 5/8" S.S. sheet metal screws for all other lower level components.
- 4.) Flasher and electronic boxes may be replaced at this step. They are attached using a 8-32 X 1" S.S. machine screw.
- 5.) Make sure that all components and electrical leads are attached before reassembly. The midplate must be temporarily grounded to the frame if recommended electrical testing is done before reassembly. (Rotators will not operate.) Reassemble in reverse order being careful not to pinch the chassis wires.

WARNING!



High voltage and/or temperatures are present inside the unit. Disconnect from power and wait 10 minutes prior to servicing or troubleshooting. Using hand and eye protection when changing halogen lamps or flashtubes.

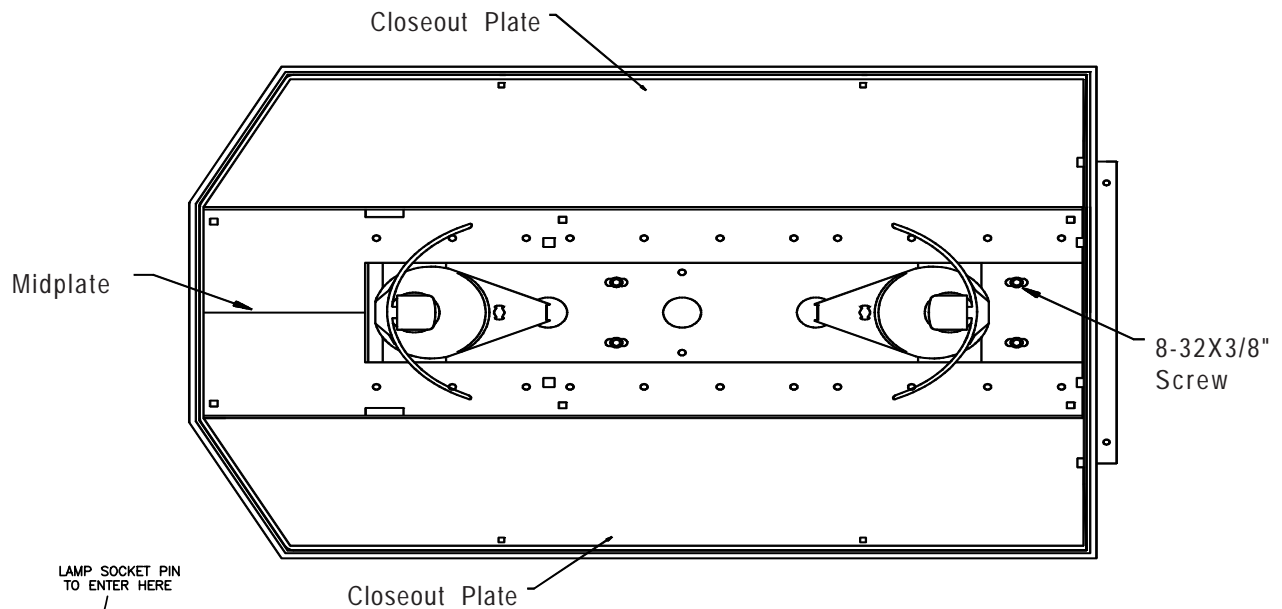
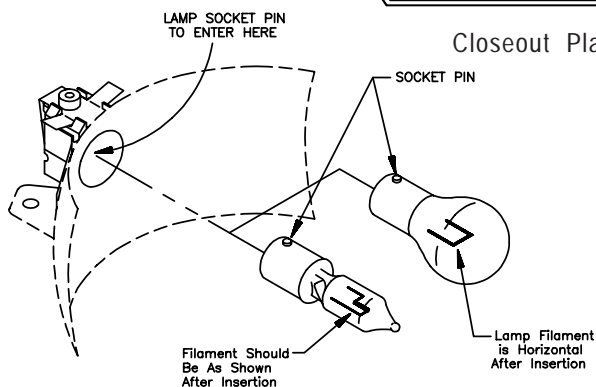

Figure 16



Lower Unit Light
Figure 15

Strobe Filter Replacement

Refer to Figure 17. The filter can be removed by unsnapping it from the light head and by removing the mirror if present for clearance. Prying the filter from the front may damage the glass strobe tube or reflector.

To replace the filter, reverse the above procedure. The filter should be fully engaged on the light head assembly. Care should be taken to not damage the strobe tube or to scratch the reflective surface of the reflector when replacing the filter.

Strobe Light Head Replacement

Refer to Figure 17. Disconnect the light head assembly from the strobe power supply and remove the filter if any. Unfasten the screws attaching the light head mounting bracket to the light bar chassis and remove the light head from the light bar. On a bench or other work suitable work surface unfasten the screws attaching the strobe light head assembly from the light head mounting bracket. Install the new strobe light head assembly to the light head mounting bracket and reinstall the light head back onto the light bar chassis. Reconnect the light head wiring to the strobe power supply and reattach the filter. It is important to reroute and secure the wiring as close as possible to its original position.

Caution, verify that no wires are interfering with the operation of the fan located at the end of the power supply.

Electronics Module Removal

In the event that the power supply or a strobe lamp assembly must be returned to the factory for service, mark each wire with a tag to identify each function and note the proper location before disconnecting the wiring. Figure 18 can be used to mark the locations of the individual connections as well.

Refer to Figure 18 for power supply removal. Remove the four (4) screws holding the power supply. Disconnect the wire leads, and move the power supply to the side. Remove the 2 screws holding the capacitor assembly and lift the strobe power supply/capacitor assembly from the lightbar as a unit. To reinstall the power supply reverse the above steps.

Caution: Verify that wires are not pinched or damaged when reinstalling power supply.

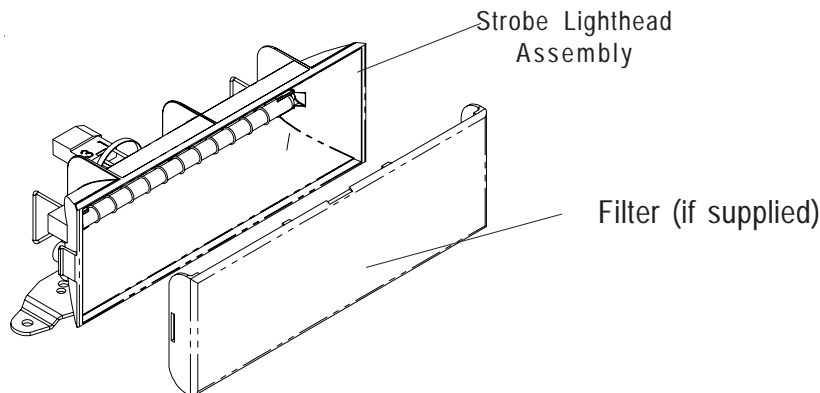

FIGURE 17

The power supply can be located in three locations - Driver's side and Passenger's side outboards and the center section. The power supply location will depend on the configuration of the MX Strobe lightbar.

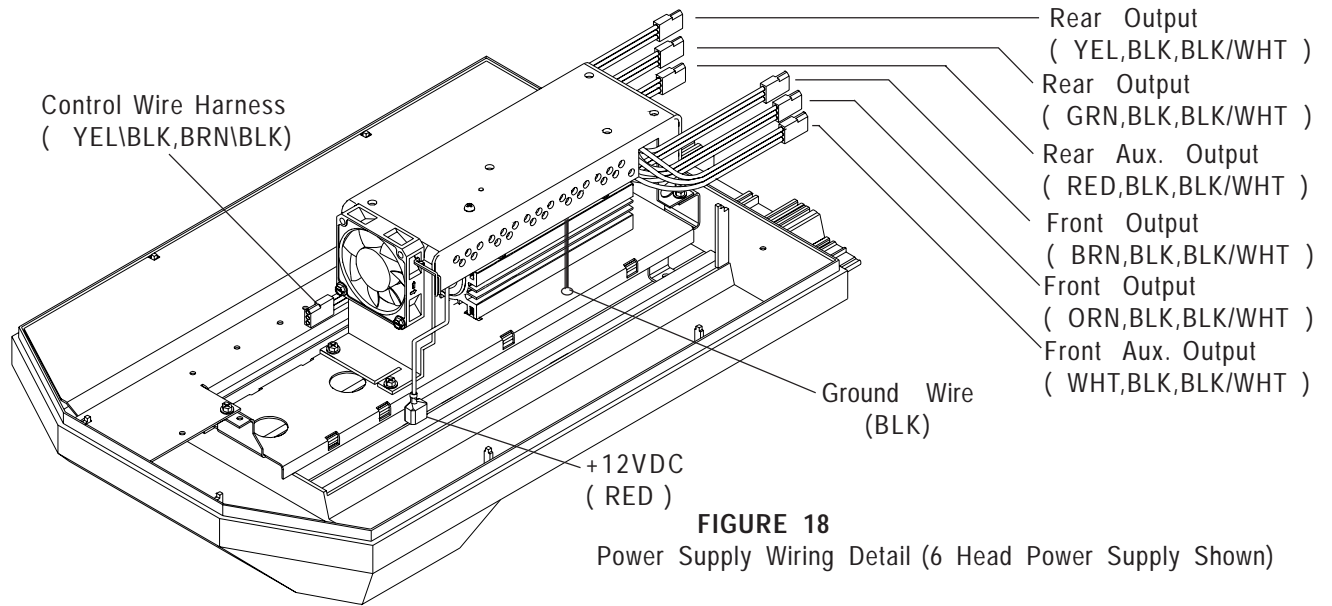
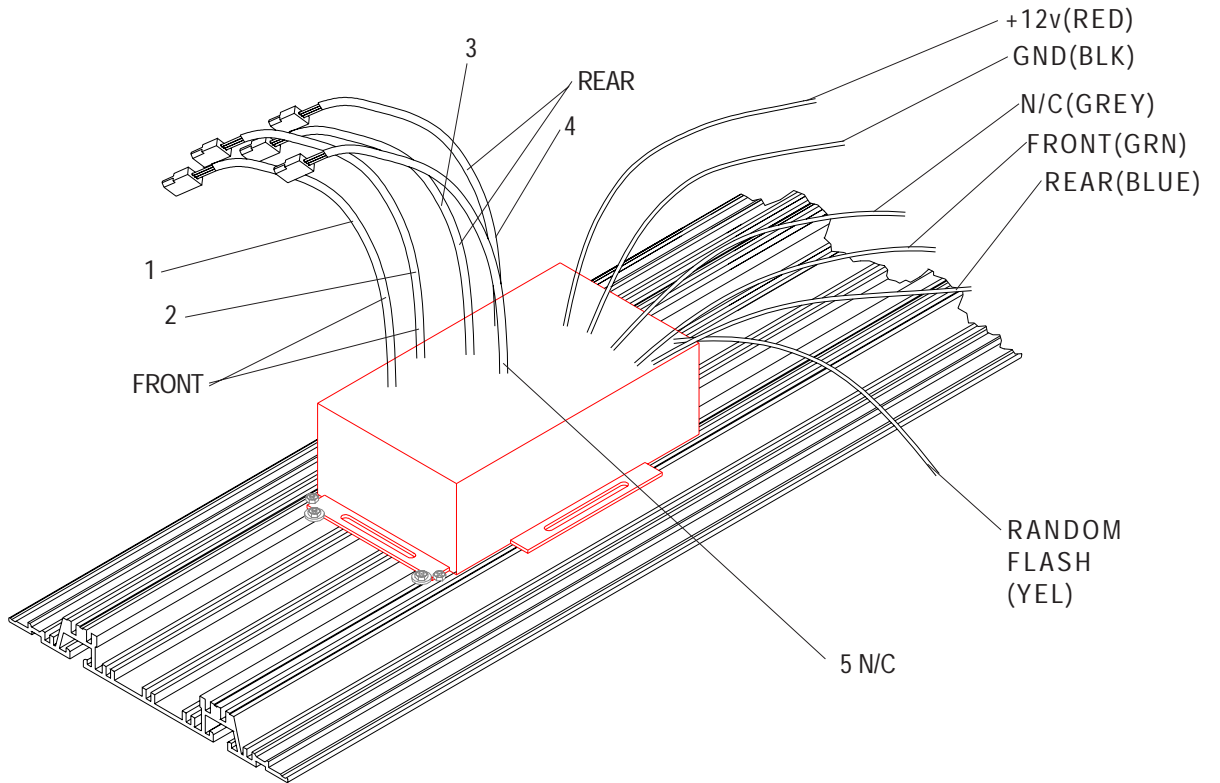

FIGURE 18
Power Supply Wiring Detail (6 Head Power Supply Shown)



PSE 490E

FIGURE 18A

MX 7000 Exploded View - Outboard Section Shown

Figure 19

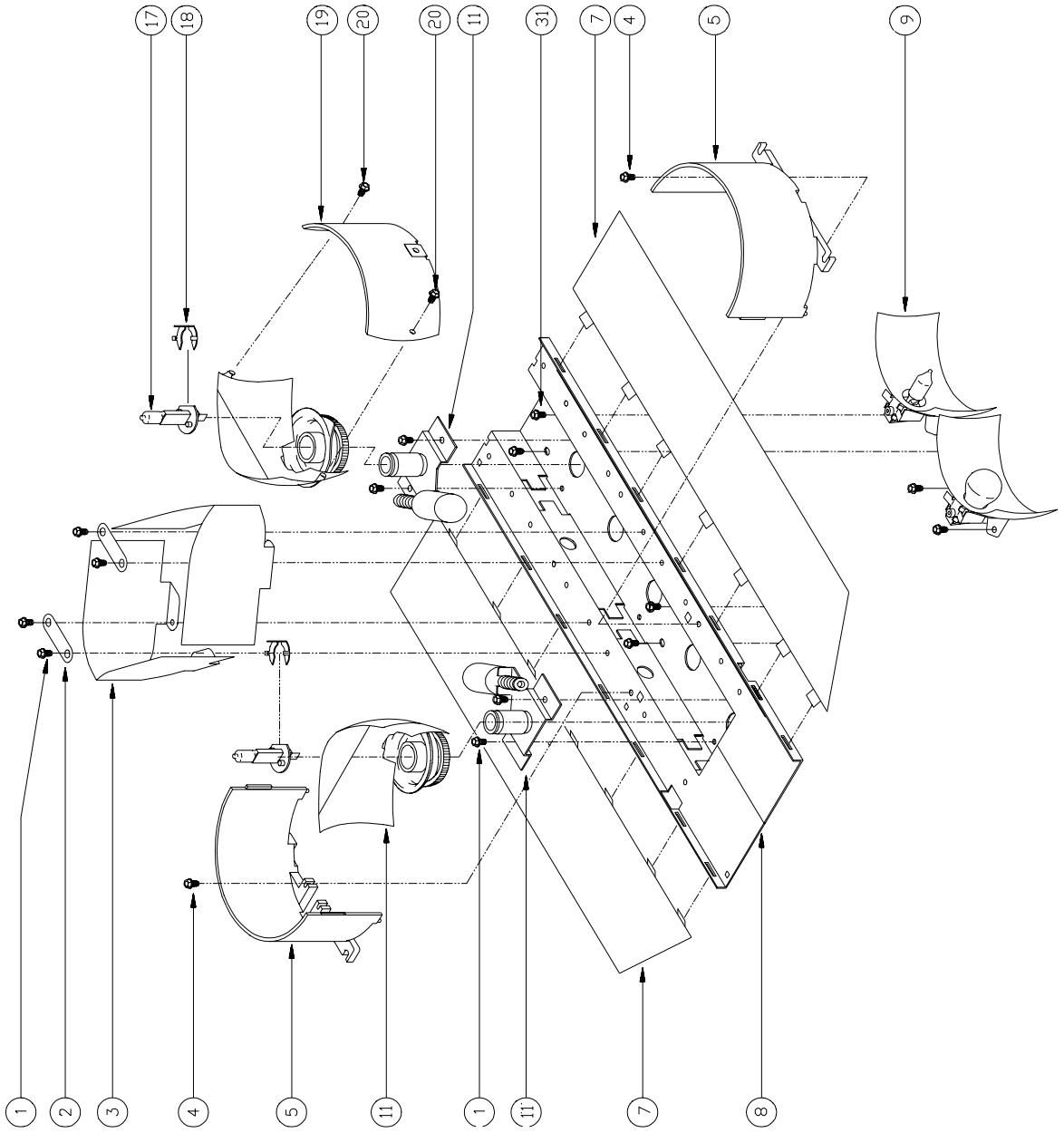

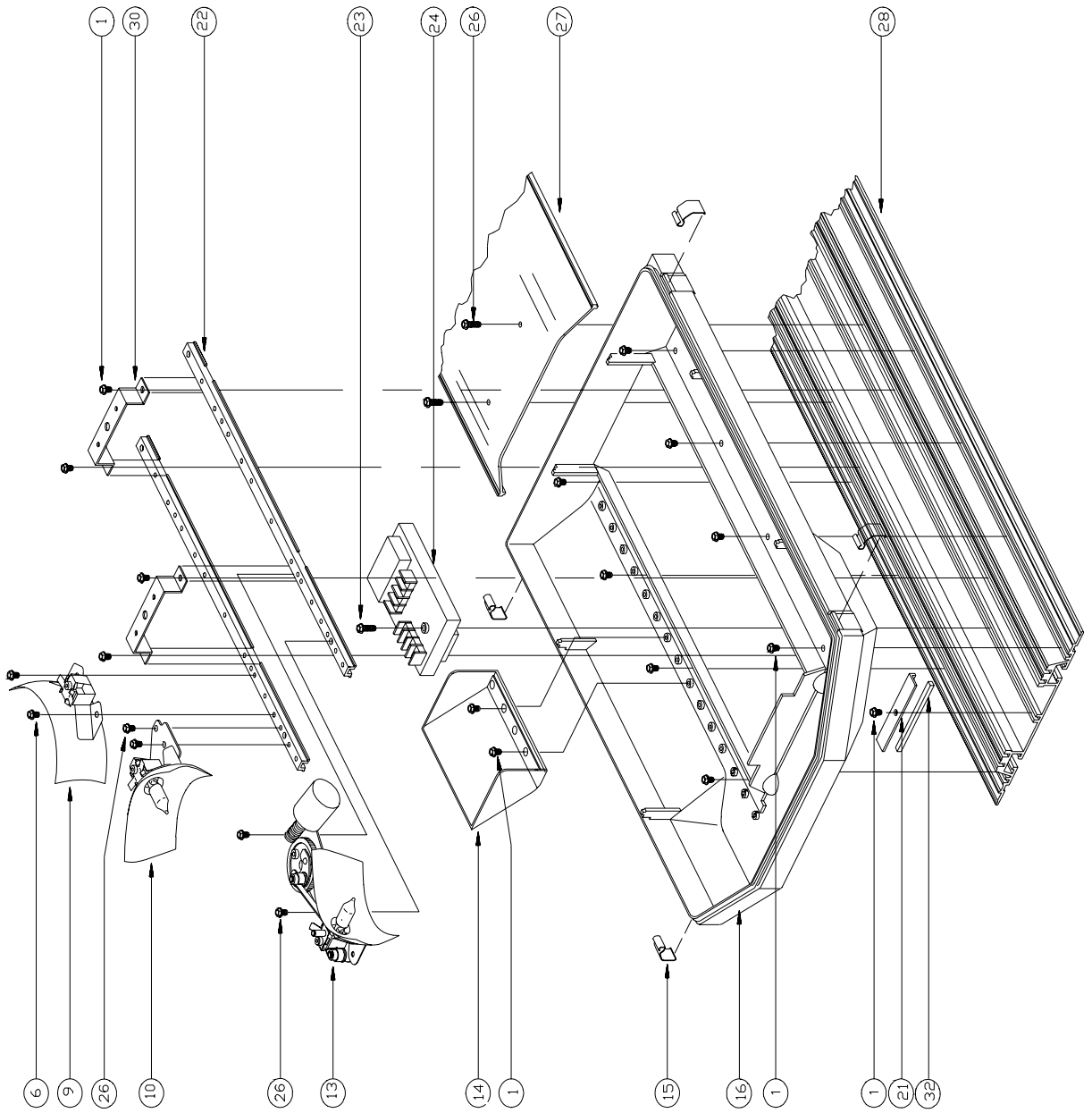

Parts List

<u>Ref No.</u>	<u>Description</u>	<u>Part No.</u>
1	#8 x .270" Sheet Metal Screw	T01215
2	MX Torque Plate	T08637
3	MX 1/2 Diamond Mirror	S25408M
	MX Full Diamond Mirror	S13625M
4	#8 x 3/8" Sheet Metal Screw	T00243
5	MX Cyl. Filter Green - 2250, Red - 2252, Blue - 2253, Amber - 2254	T0225X
6	#8-1/2" Sheet Metal Screw	T00238
7	MX Closure Plate Outboard	T05308
8	MX Outboard Midplate	S50265M
9	MX S795 Stationary Module	S50346M
	MX 1156 Stationary Module	S50348M
10	D.S. Alley Light Module	S50361M
	P.S. Alley Light Module	S50362M
11	Rotator Module 55W H-1 Std Speed	S95983M
	Rotator Module 55W H-1 Fast Speed	S95984M
	Rotator Module 50W Bayonet Std Speed	S95985M
	Rotator Module 50W Bayonet Fast Speed	S95986M
	Rotator Module 24V	S95987M
13	MX Osc. D.S. Front 120° Intersection Module	S50406M
	MX Osc. P.S. Front 120° Intersection Module	S50407M
	MX Osc. D.S. Fast Front 70° Pursuit Module	S50408M
	MX Osc. P.S. Fast Front 70° Pursuit Module	S50409M
	Multi Function Intersection D.S. Module	S50690M
	Multi Function Intersection P.S. Module	S50691M
14	5-Hole Stationary Filter with Optics Green - T02550, Red - T02552, Blue - T02553, Amber - T02554	T0255X
	5-Hole Stationary Filter without Optics Green - T02090, Red - T02092, Blue - T02093, Amber - T02094	T0209X
	3-Hole Stationary Filter Green - T02140, Red - T02142, Blue - T02143, Amber - T02144, Black - T02146, Translucent White - T02147	T0214X
15	Lens Clip	T01777
16	MX Bottom Lens - Clear	S50260M
17	H-1 55W 12V Bulb	T01543
	S795 50W 12V Bulb	T01540
18	H-1 Lamp Retaining Clip	T04933
19	Rotating Filter for free form reflector with mtg. screws Green - S95988M, Red -S95989M, Blue - S95990M, Amber - S95991M	
20	Screw, 2 X 3/8 Pan HD	T02655
21	Splash Bracket	T09330
22	MX Outboard Locator Strip	T05022
23	#8-32 X 1" Machine Screw	T04884
26	#8 X 5/8" Sheet Metal Screw	T02921
27	MX Speaker Deck Assembly	S25399M
28	MX Regular Frame	S50354M
30	Midplate Mounting Bracket	T04810
31	#8-32 X 3/8" Sheet Metal Screw	T04888
32	3/8" X 3/8" Open Cell Foam	T02919

PARTS NOT SHOWN

MX Top Outboard Lens	
Clear	T02101
Red	T02102
Blue	T02103
Amber	T02104
Terminal Block - 2 Pole, 1 Row	T00028
5/16" Cable Clamp	T00346
1/2" Cable Clamp	T00903
3/8" Cable Clamp	T00938
3/4" Snap Bushing	T00336
MX Cornering Filter - (D.S. Front/P.S. Rear)	
Red	T02182
Blue	T02183
Amber	T02184
Black	T02186
MX Cornering Filter - (D.S. Rear/P.S. Front)	
Red	T02192
Blue	T02193
Amber	T02194
Black	T02196

OPTIONS NOT SHOWN

MX StingRay™ Module (S795)	S50400M
P.S. 2-Step Cascade Mirror	S55006M
D.S. 2-Step Cascade Mirror	S55009M
MX Flat Mirror Outbd.-Driver Front or Passenger Rear	T04278
MX Flat Mirror Outbd.-Driver Rear or Passenger Front	T04279
MX 104° V-Mirror	S55012M
MX Stop/Turn/Tail Light Assembly Upper W/Adapter Plate	S50296M
MX Stop/Turn/Tail Light Assembly Lower	S50342M
MX External D.O.T. Strip Assembly	S50021M
MX Closure Plate Center	T05307
MX Center Locator Strip	T05021
MX Center Midplate	T05386
MX Center Midplate Module	S50264M
MX Top Center Lens	
Clear	T02131
Red	T02132
Blue	T02133
Amber	T02134
White	T02137
MX Bottom Center Lens Module - Clear	S25444M
OsciLaser Module 35W	S50343M
Multi-Functional Control Box	S55401M

Parts & Exploded Views - Outboard Section
 For Additional Parts, see MX7000 Bar Manual

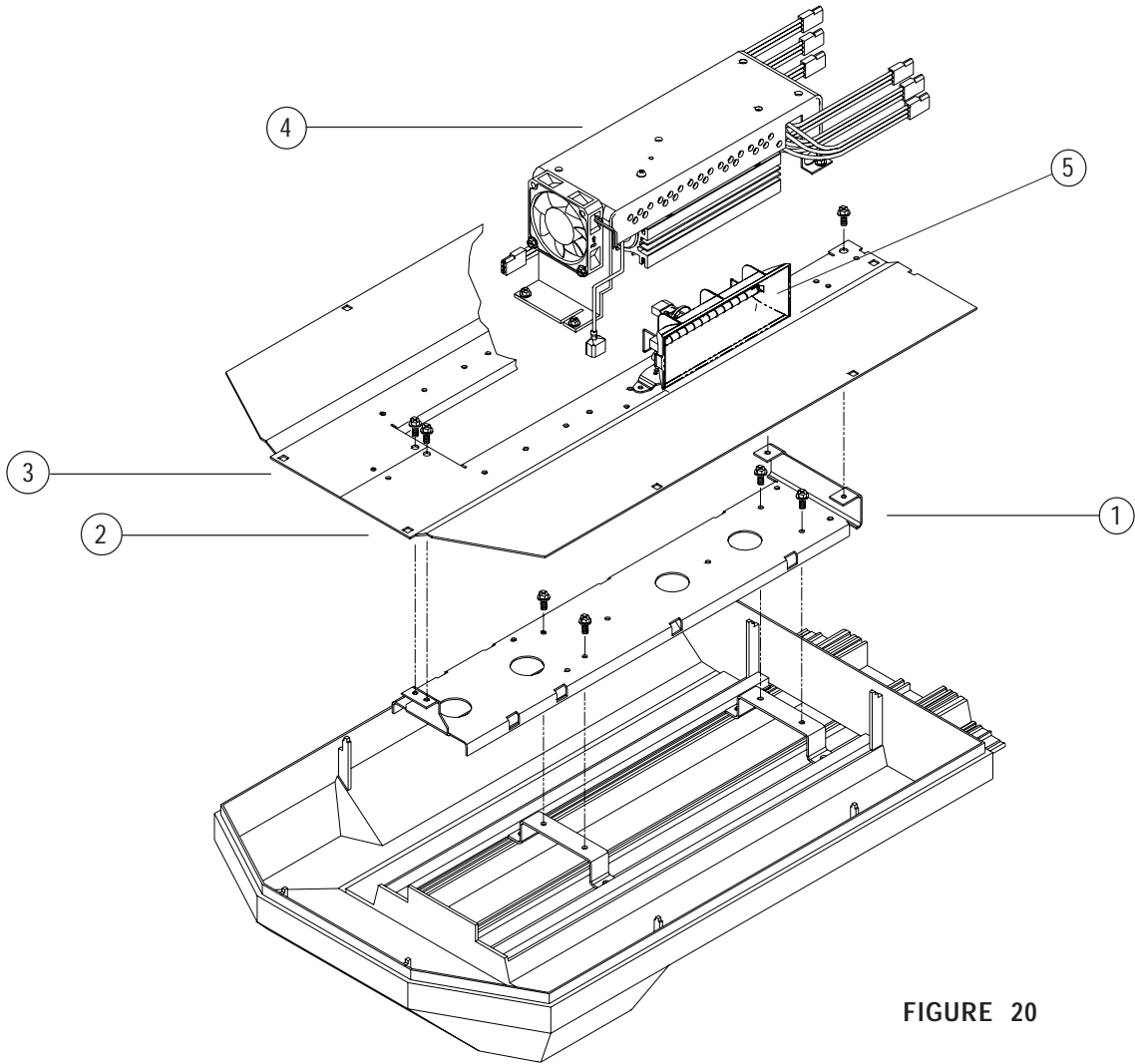

FIGURE 20

Parts list

<u>No.</u>	<u>Description</u>	<u>Part No.</u>	<u>Qty</u>
1	MX Strobe Motor Plate	T08604	2
2	MX Strobe Midplate - Front	T08602	2
3	MX Strobe Midplate - Rear	T08603	2
4	MX Strobe Power Supply Assembly, 6 Head	S80352M	1
	MX Strobe Power Supply Assembly, 4 Head	S80305M	1
	MX Strobe Power Supply Assembly, 2 Head	S80310M	1

Parts & Exploded Views- Outboard Section

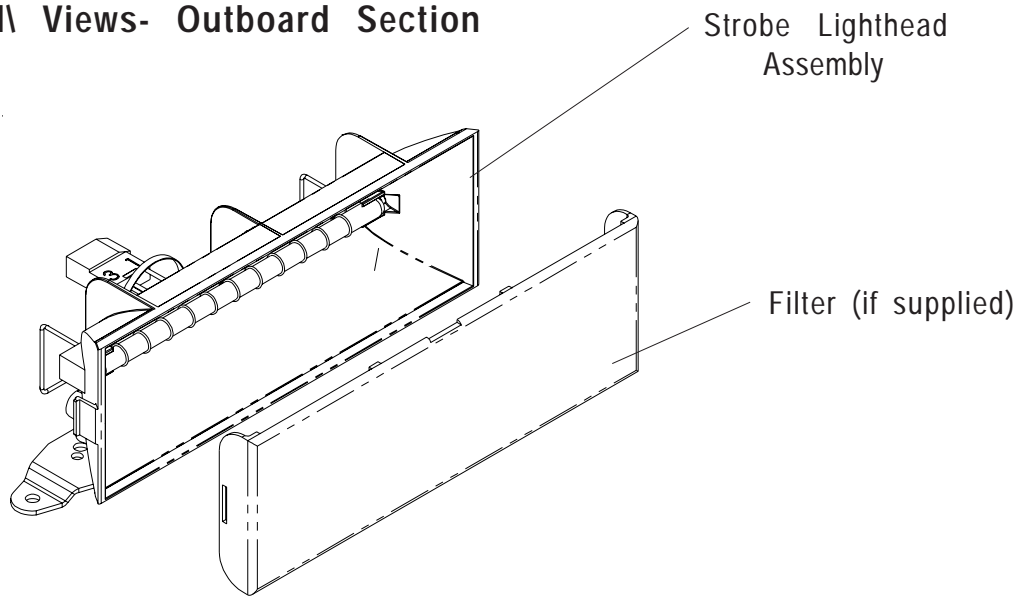
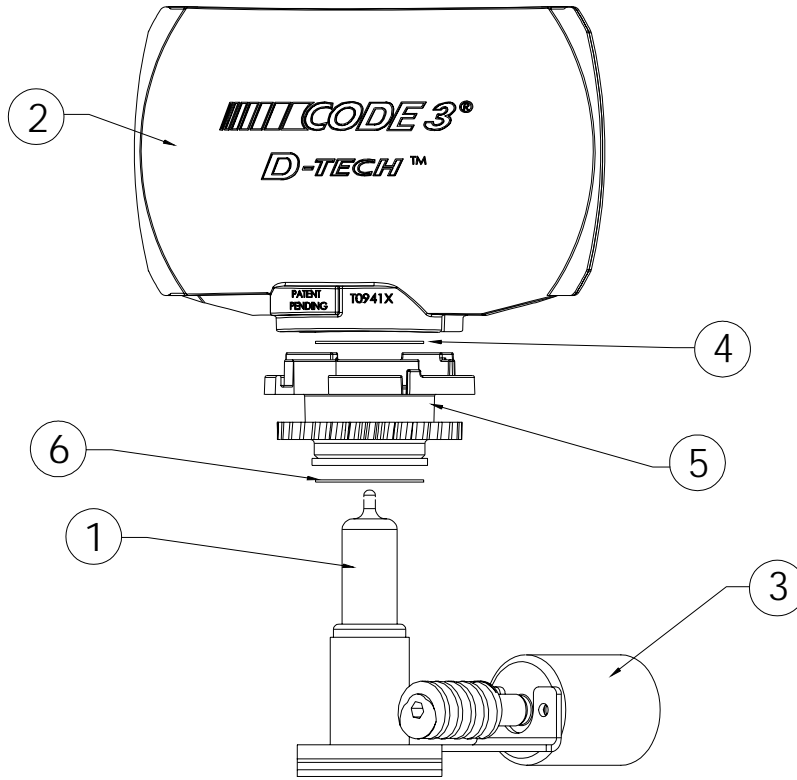

FIGURE 21

Parts List

<u>No.</u>	<u>Description</u>	<u>Part No.</u>	<u>Qty.</u>
5	Strobe Upper Lighthouse Assembly - Corner Position	T09424	
	Strobe Upper Lighthouse Assembly - Corner Position Mirror - DS Frt/PS Rr	T09409	
	Strobe Upper Lighthouse Assembly - Corner Position Mirror - PS Frt/DS Rr	T09406	
	Strobe Upper Light Head Assy – Corner Pos Filter		
	Red	T09442	
	Blue	T09443	
	Amber	T09444	
	Strobe Upper Light Head Assembly – Directional Position	T09425	
	Strobe Upper Light Head Assy – Directional Pos Filter		
	Red	T09432	
	Blue	T09433	
	Amber	T09434	

D-TECH ROTATOR



	DESCRIPTION	PART NO.
1	BAYONET LAMP 50W	T01540
2	NEW REFLECTOR ASSEMBLY RED/BLUE AMBER/BLUE	S22179 T02652
3	MOTOR ASSEMBLY MX, CODE360 FAST MX, CODE360	S95872M S95873M
4	RETAINING RING	T01210
5	D-TECH ROTATOR BASE ASS	S14050M
6	NYLON WASHER	T04492

D-Tech Lamp Replacement Instructions

To remove lamp, first remove D-Tech Reflector Head. Press DOWN on tab and rotate D-Tech head counterclockwise to remove.

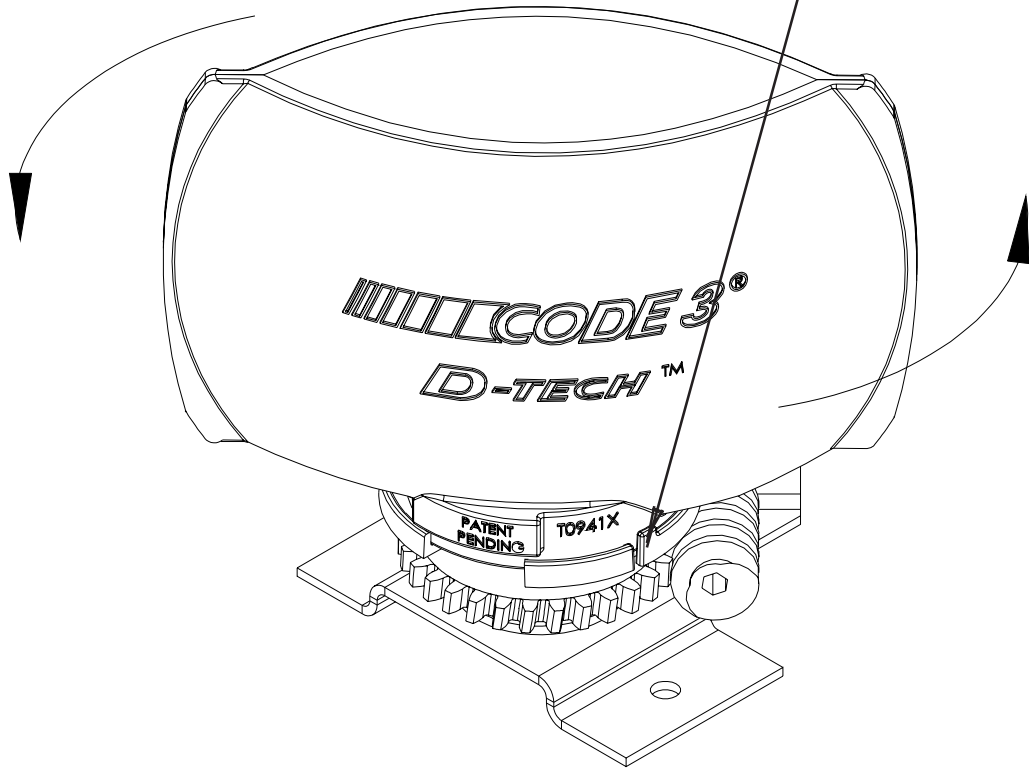

Troubleshooting

All Excalibur strobe lightbars are thoroughly tested prior to shipment. However, should you encounter a problem during installation or during the life of the product, follow the guide below for information on repair and troubleshooting. Additional information may be obtained from the factory technical help line at 314-426-2700 ext. 2131.

NO STROBE LIGHTS IN THE LIGHTBAR OPERATE - Check the following: 1) +12 VDC source connection for the control switch box and any in line fuse 2) Connection of the RED and RED/BLK wire at the control switch box 3) Check the 15 Amp ATO fuse on each power supply. If the fuse is blown, replace it with another **15 Amp fuse** and test the lightbar. If the fuse continues to blow, return the power supply only, NOT the entire lightbar, to the factory for service. For instructions on power supply removal see the " Electronics Module Removal " section of this manual.



Do not replace the fuse with one of a higher rating. This will damage the power supply and void all warranties.

WARNING!

ONE STROBE LIGHT MODULE DOES NOT OPERATE - Check the defective strobe light module by switching it with a module that is known to be working.

PROBLEM	POSSIBLE CAUSE	SOLUTION
Lighthouse oscillates when selecting Alley and/or Takedown modes.	Lighthouse not sensing position. Check the following: Bad wiring harness Bad connection Failed position sensor	Replace wiring harness Check connections (Figure 10 & 11) Replace lighthouse assembly
Lighthouse doesn't move when Alley and/or Takedown mode is selected, but moves in Intersection mode	Failed lighthouse assembly	Replace lighthouse assembly
Lighthouse does not move when any mode is selected.	Bad motor wire to module Failed light bar wire harness No power to control module Failed lighthouse assembly Failed control module	Check connections / Replace wire Check light bar wiring harness Check +12VDC switching control Replace lighthouse assembly Replace control module
Lighthouse operates properly, but lamp is not on	Lamp burnt out Bad lamp wire to module	Replace lamp (50W maximum) Check connections / Replace wire
Driver side lighthouse oscillates and Passenger side lighthouse does not move when Takedown is selected. Note: In Takedown mode, Passenger side lighthouse will not move until Driver side lighthouse has located	Driver side lighthouse not sensing Check for the following: Bad wiring harness Bad wiring harness connection Failed position sensor	Replace wiring harness Check connections (Figure 10 & 11) Replace lighthouse assembly
Intersection mode selected, Driver and Passenger side Alley modes do not function	No problem	Normal operation, Intersection mode overrides Alley mode.
Takedown mode selected, no other modes operational	No problem	Normal operation, Takedown mode overrides all other modes

STROBE OPTION

TROUBLESHOOTING GUIDE

PROBLEM	CAUSE	SOLUTION
Light heads do not fire.	<ul style="list-style-type: none"> a. Harness that connects power supply to strobe head has loose connections or damaged harness. b. Faulty strobe Lighthouse. c. High voltage shorting to ground (earth) through harness. 	<ul style="list-style-type: none"> a. Check all connections. Check harness by switching harness with functioning strobe head. Replace harness. b. Check with known good Lighthouse. c. Isolate shorted harness by disconnecting one at a time. Replace harness.
Only front strobes flash.	<ul style="list-style-type: none"> a. GRN/BLK control wire connected to +12VDC overrides other modes. 	<ul style="list-style-type: none"> a. See "Strobe Lighting Connections" section. Reconnect switching.

Follow the guide below for information on repair and trouble shooting for the arrowstik option.

ARROWSTIK® OPTION

TROUBLESHOOTING GUIDE

PROBLEM	QUESTION	CAUSE	SOLUTION
ArrowStik does not function when turned on	Are LED's functioning properly? <div style="text-align: right;"> Yes No </div>	<ul style="list-style-type: none"> a. Plug in rear of control box is loose or disconnected. b. Poor ground connection a. Power from battery has been disconnected or the control box has been damaged.	<ul style="list-style-type: none"> a. Reconnect plug. b. Reconnect ground. a. Check connections at the battery and plug. If connections are good and voltage is at least 10 volts, the control box has been damaged. Repair or return to Code 3.
Lamp does not come on when it should.	Are LED's functioning properly? <div style="text-align: right;"> Yes No </div>	<ul style="list-style-type: none"> a. Lamp has burned out. b. Bad wiring connection. a. Control box has been damaged.	<ul style="list-style-type: none"> a. Replace lamp. b. Repair connection. a. Repair or return to Code 3.
Right most lamp does not come on in Arrow Left mode or left most lamp does not come on in Arrow Right mode.		<ul style="list-style-type: none"> a. Normal operation 	<ul style="list-style-type: none"> a. None
ArrowStik runs opposite pattern than selected.		<ul style="list-style-type: none"> a. Defective Wiring. b. Control box has been damaged. 	<ul style="list-style-type: none"> a. Check that the cable exit is on the driver's side b. Repair or return to Code 3. a. Repair or return to Code 3.
Lamp looks dim.		<ul style="list-style-type: none"> a. Defective lamp. b. Low voltage. c. Poor ground d. Product is in "Dim" mode. 	<ul style="list-style-type: none"> a. Replace lamp. b. Check connections or battery. c. Check ground and wire gauge. d. Select appropriate mode.

NOTES

NOTES

NOTES

WARRANTY

This product was tested and found to be operational at the time of manufacture. Provided this product is installed and operated in accordance with the manufacturer's recommendations, Code 3®, Inc. guarantees all parts and components except the lamps for a period of 1 year from the date of purchase or delivery, whichever is later. Units demonstrated to be defective within the warranty period will be repaired or replaced at the factory service center at no cost.

Use of a lamp or other electrical load of a wattage higher than installed or recommended by the factory, or use of inappropriate or inadequate wiring or circuit protection causes this warranty to become void. Failure or destruction of the product resulting from abuse or unusual use and/or accidents is not covered by this warranty.

Code 3® shall in no way be liable for other damages including consequential, indirect or special damages whether loss is due to negligence or breach of warranty.

CODE 3® MAKES NO OTHER EXPRESS OR IMPLIED WARRANTY INCLUDING, WITHOUT LIMITATION, WARRANTIES OF FITNESS OR MERCHANTABILITY, WITH RESPECT TO THIS PRODUCT.

PRODUCT RETURNS

In order to provide you with faster service, if you are going to return a product for repair or replacement*, please contact our factory to obtain a Return Goods Authorization Number (RGA number) before you ship the product to Code 3®. Write the RGA number clearly on the package near the mailing label. Be sure you use sufficient packing materials to avoid damage to the product being returned while in transit.

*Code 3® reserves the right to repair or replace product at its discretion. Code 3 assumes no responsibility or liability for expenses incurred for the removal and/or reinstallation of products requiring service and/or repair.

Code 3, Inc.
10986 N. Warson Road
St. Louis, Missouri 63114-2029—USA
Ph. (314) 426-2700 Fax (314) 426-1337
www.code3pse.com