

INSTALLATION & OPERATION MANUAL



FOR LED X™ 2100
LIGHTBAR

Code 3, Inc., a subsidiary of
Public Safety Equipment, Inc.



LED X™ 2100 LIGHT BAR

CONTENTS:

Introduction.....	2
Unpacking & Pre-Installation.....	3
Installation & Mounting.....	3-5
Wiring Instructions.....	5-6
Options & Specifications.....	6-10
Maintenance.....	10-11
Parts List (Replacement Parts / Exploded View).....	12-13
Trouble Shooting.....	14-15
Warranty.....	16

For future reference record your lightbar's serial no. here _____

IMPORTANT: *Read all instructions and warnings before installing and using.*
INSTALLER: *This manual must be delivered to the end user of this equipment.*

Introduction

The LED X™ 2100 Light Bar is a light bar that is approximately 2" high, yet delivers unobstructed 360° warning and more signal power and versatility than any other light bar of its size.

The low profile and aerodynamic lines reduce air drag, which results in fuel savings and stability at high speeds. This light bar has a strong extruded internal frame, shock-resistant polycarbonate lenses, and warning signals that exceed SAE standards.

The LED X 2100 is designed on a modular basis, which means that the light bar can be customized to meet any requirement. The LED X 2100 has room for numerous halogen, incandescent and LED options. While we do not recommend a light installed in every location, the design of the LED X 2100 offers the ultimate flexibility in the location of warning and auxiliary lights.



WARNING!

The use of this or any warning device does not ensure that all drivers can or will observe or react to an emergency warning signal. Never take the right-of-way for granted. It is your responsibility to be sure you can proceed safely before entering an intersection, driving against traffic, responding at a high rate of speed, or walking on or around traffic lanes.

The effectiveness of this warning device is highly dependent upon correct mounting and wiring. Read and follow the manufacturer's instructions before installing or using this device. The vehicle operator should insure daily that all features of the device operate correctly. In use, the vehicle operator should insure the projection of the warning signal is not blocked by vehicle components (i.e.: open trunks or compartment doors), people, vehicles, or other obstructions.

This equipment is intended for use by authorized personnel only. It is the user's responsibility to understand and obey all laws regarding emergency warning devices. The user should check all applicable city, state and federal laws and regulations.

Code 3, Inc., assumes no liability for any loss resulting from the use of this warning device.

Proper installation is vital to the performance of this warning device and the safe operation of the emergency vehicle. It is important to recognize that the operator of the emergency vehicle is under psychological and physiological stress caused by the emergency situation. The warning device should be installed in such a manner as to: A) Not reduce the output performance of the system, B) Place the controls within convenient reach of the operator so that he can operate the system without losing eye contact with the roadway.

Emergency warning devices often require high electrical voltages and/or currents. Properly protect and use caution around live electrical connections. Grounding or shorting of electrical connections can cause high current arcing, which can cause personal injury and/or severe vehicle damage, including fire.

PROPER INSTALLATION COMBINED WITH OPERATOR TRAINING IN THE PROPER USE OF EMERGENCY WARNING DEVICES IS ESSENTIAL TO INSURE THE SAFETY OF EMERGENCY PERSONNEL AND THE PUBLIC.

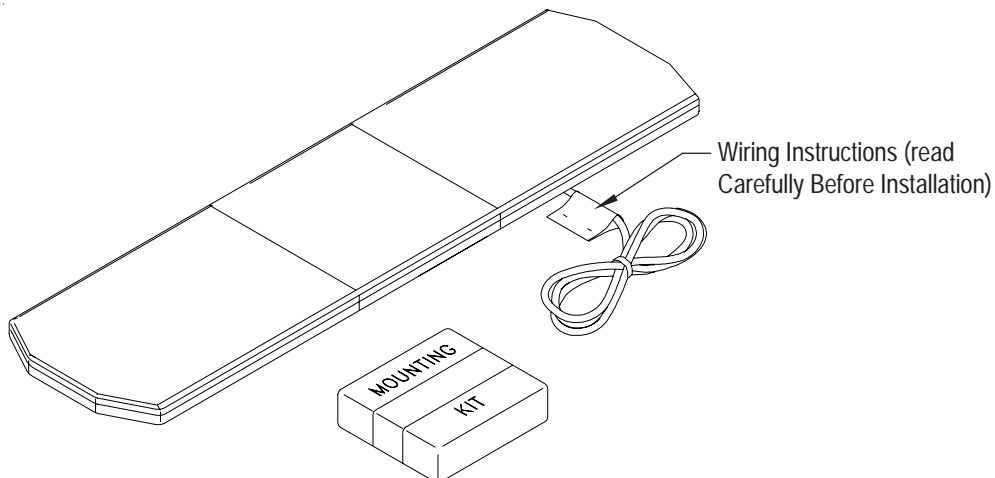

Unpacking & Pre-installation

Carefully remove the light bar and place it on a flat surface, taking care not to scratch the lenses or damage the cable coming out of the bottom. Examine the unit for transit damage, broken lamps, etc. Report any damage to the carrier and keep the shipping carton.

Standard light bars are built to operate on 12 volt D.C. negative ground (earth) vehicles. If you have an electrical system other than 12 volt D.C. negative ground (earth), and have not ordered a specially wired light bar, contact the factory for instructions.

Test the unit before installation. To test, touch the black wire to the ground (earth) and the other wires to +12 volts D.C., in accordance with the instructions attached to the cable (an automotive battery is preferable for this test). A battery charger may be used, but please note that some electronic options (flashers, stingrays, etc.) may not operate normally when powered by a battery charger. If problems occur at this point, contact the factory.

Installation & Mounting

WARNING!  Utilizing non-factory supplied screws and/or mounting brackets and/or the improper number of screws may result in loss of warranty coverage on the equipment.

MOUNTING HARDWARE - All mounting hardware is packed in a small box inside the main carton. Four standard kits are available: (1) Hook-On Type, (1) Tow and Recovery and (2) Permanent Types. These are discussed in detail later. **Note:** Hook-on mounting for "gutterless" type vehicles will require a special hook for mounting. Several special application hooks are available. Contact the factory for details.

Hook-on Mounting

Begin the installation by attaching the rubber feet to the mounting brackets using the black 1/4" carriage bolts and 1/4" nuts provided. See Figure 1. (Do not install shims at this time). Place the light bar upside down on a table or other work surface, being careful not to scratch the lenses. Slide the 5/16" carriage bolts into the frame. Secure the mounting brackets finger tight so they support the weight of the light bar, but still are positionable. Locate the vehicle on a level surface. Place the light bar on the roof of the vehicle. Place a soft pad in the center of the roof to protect the paint. The mounting brackets must be placed so that the rubber feet are resting on the curved section of the roof, see Figure 2. This is the strongest part of the roof. Once the light bar is centered, tighten the mounting bracket to the light bar. Using a tape measure and a level, center the light bar from side to side and locate a position on the roof where the light bar is level.

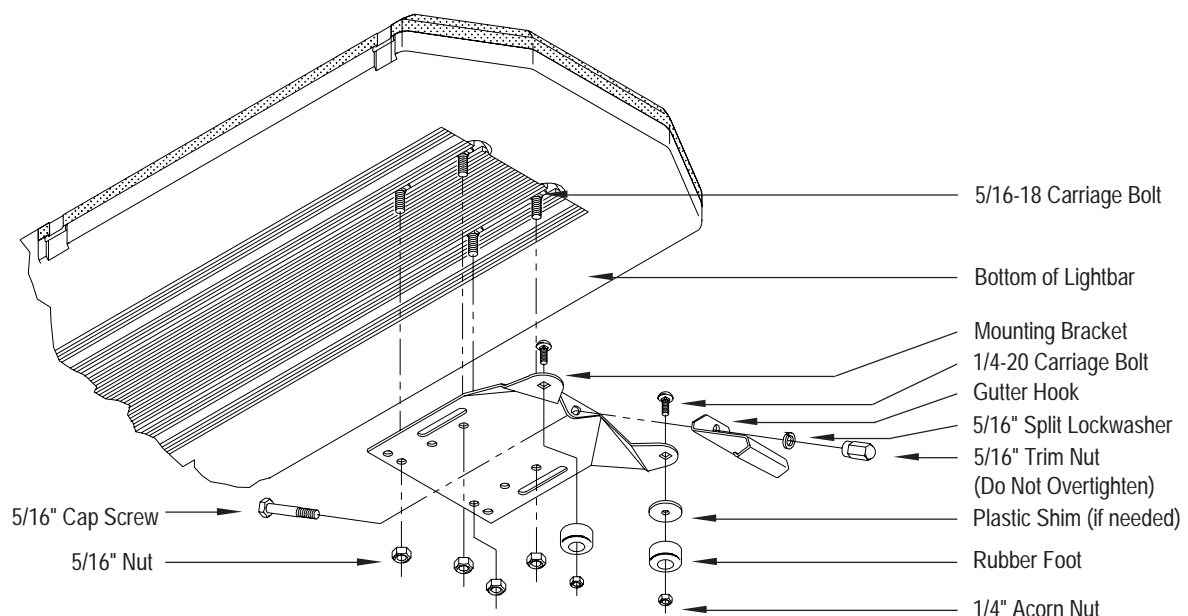

FIGURE 1

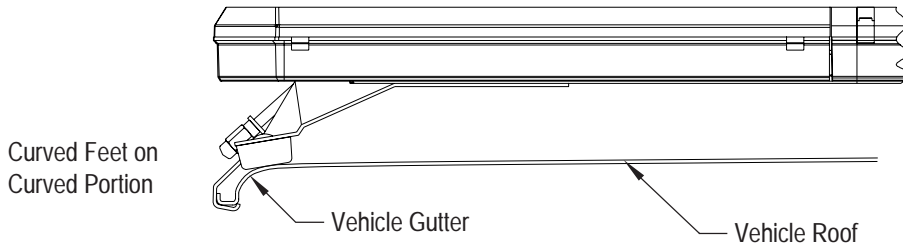

FIGURE 2

The shims provided may be used here to help level the light bar, see Figure 1. Also, the tabs on the mounting brackets may be bent at any angle to match the curvature of the roof. Select the appropriate length cap screw and insert through the holes in the gutter hook and mounting bracket, and into a lockwasher and acorn nut as shown in Figure 1. If a special hook for a "gutterless" vehicle is used, refer to the instructions for that hook at this time. The stainless steel cap screws supplied are sized for the most common installations, but longer and shorter bolts are available at any hardware store. Tighten the cap screws on both sides evenly keeping the light bar centered and level.

NOTE: Tighten only until the bar is secure (bar does not move when bumped sharply with the heel of the palm). It is NOT necessary to dimple the roof to obtain a stable attachment. If the light bar "bows" more than 3/16" (determined by placing a straightedge along the front, bottom part of the frame and measuring downward at the center of the frame), loosen the 5/16" trim nut slightly.

Re-Installation: When moving a light bar from one vehicle to another, we suggest that new rubber feet be used. These are standard hardware items, and can usually be found at any hardware store, or can be ordered from the factory. The special hooks are stainless steel and should be saved and reused. Mounting kit parts are available to permit remounting on vehicles of different design or make. Consult your local dealer or *Code 3, Inc.* for detailed information.

Permanent Mounting

Typical Mounting: Refer to Figure 3. Place the light bar upside down on a table or other work surface, being careful not to scratch the lenses. Slide the 5/16" carriage bolts into the frame. Secure the mounting brackets finger tight so they support the weight of the light bar. Place the unit on the roof of the vehicle. Place a soft pad in the center of the roof to protect the paint. The mounting brackets must be placed so that they are resting on the curved section of the roof, see Figure 4. This is the strongest part of the roof. Once the light bar is centered, tighten mounting brackets to light bar. Using a tape measure and a level, center the light bar from side to side and locate a position of the roof where the light bar is level. The shims provided may be used here to help level the light bar. Also, the tabs on the mounting bracket may be bent at any angle to match the curvature of the roof (see Figure 4).

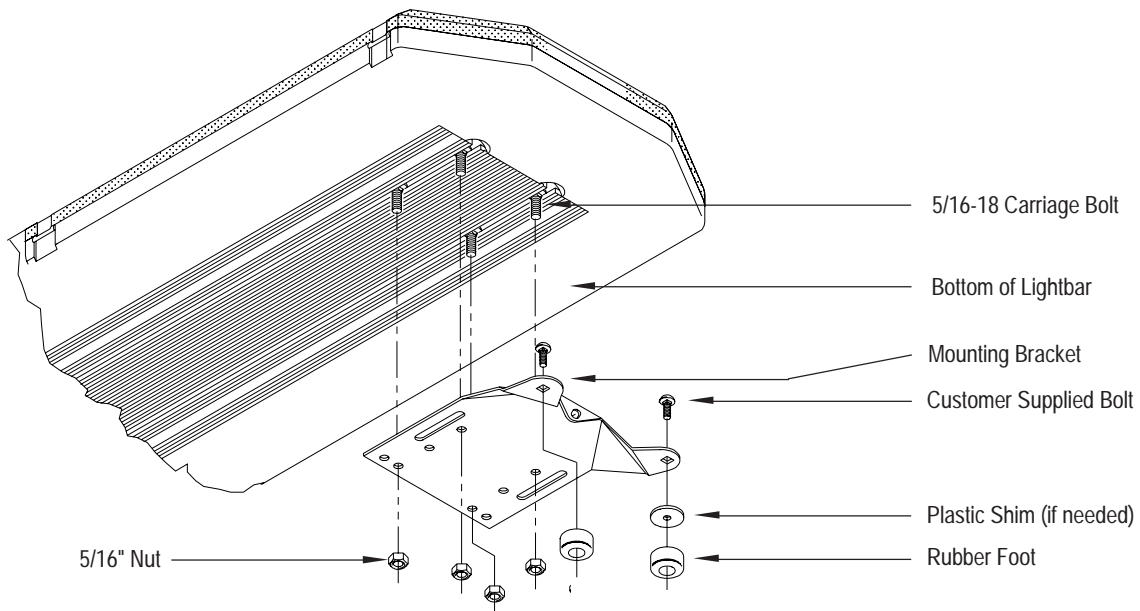
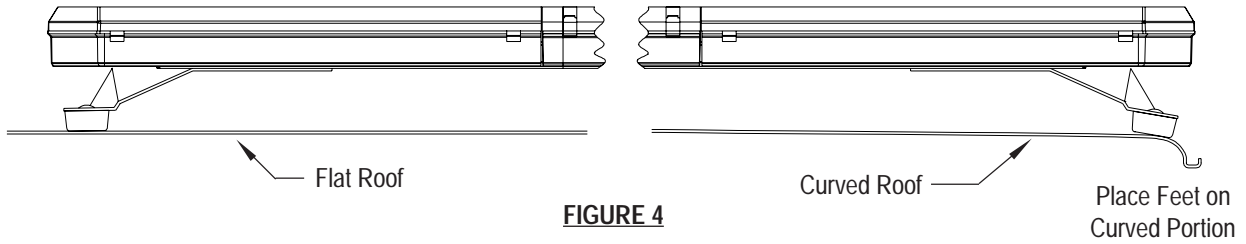

FIGURE 3



Once the light bar is level and centered, mark the holes through the mounting tabs and remove the light bar from the vehicle. Make sure that the drill will not damage anything when penetrating the roof. Drill the mounting holes and remove any burrs. Attachment can be made using 1/4" cap screws, toggle bolts, or other fasteners as may be convenient. Use sealant as necessary to prevent water leakage into the vehicle.

Wiring Instructions



WARNING!

Larger wires and tight connections will provide longer service life for components. For high current wires it is highly recommended that terminal blocks or soldered connections be used with shrink tubing to protect the connections. Do not use insulation displacement connectors (e.g. 3M® Scotchlock type connectors). Route wiring using grommets and sealant when passing through compartment walls. Minimize the number of splices to reduce voltage drop. High ambient temperatures (e.g. underhood) will significantly reduce the current carrying capacity of wires, fuses, and circuit breakers. Use "SXL" type wire in engine compartment. All wiring should conform to the minimum wire size and other recommendations of the manufacturer and be protected from moving parts and hot surfaces. Looms, grommets, cable ties, and similar installation hardware should be used to anchor and protect all wiring. Fuses or circuit breakers should be located as close to the power takeoff points as possible and properly sized to protect the wiring and devices. Particular attention should be paid to the location and method of making electrical connections and splices to protect these points from corrosion and loss of conductivity. Ground terminations should only be made to substantial chassis components, preferably directly to the vehicle battery. The user should install a fuse sized to approximately 125% of the maximum Amp capacity in the supply line to protect against short circuits. For example, a 30 Amp fuse should carry a maximum of 24 Amps. **DO NOT USE 1/4" DIAMETER GLASS FUSES AS THEY ARE NOT SUITABLE FOR CONTINUOUS DUTY IN SIZES ABOVE 15 AMPS.** Circuit breakers are very sensitive to high temperatures and will "false trip" when mounted in hot environments or operated close to their capacity.

Before attempting to connect wiring refer to wire tag attached to the lightbar's main cable. Each wire in the cable controls a separate lightbar function as described in the wire tag.

The only significant difference between the LED X™ 2100 with optional ArrowStik® and a conventional LED X 2100, is the additional, thinner cable exiting the bottom of the lightbar. The larger cable is the lightbar power cable. Route the wiring cable into the engine or passenger compartment, taking care to use grommets and to apply sealant around openings to keep water out. It is advisable to leave an extra loop of cable when installing the light bar to allow for future changes or reinstallations. Connect the black lead to a solid frame ground (earth), preferably, the (-) or ground (earth) side of the battery and bring the other wires to the control head or switches. Connect the wires as directed by the wiring instructions on the cable.

Arrowstik® / Narrowstik®

OPTIONAL HALOGEN ARROWSTIK® (7-wire) / L.E.D. NARROWSTIK® (11-wire) WIRING AND CONTROL HEAD INSTALLATION - After installation of the lightbar, route the smaller of the two power cables through the vehicle to the location chosen for the control head. Cut the cable to length and strip back the outer insulation to expose the seven or eleven colored wires. Strip back 1/8" - 1/4" of colored insulation from each of the wires in the cable. Connect these wires to the seven position / eleven position terminal plug enclosed in the user parts bag, according to the diagram on the bottom of the control head.

- Refer to the control head manual packaged with the lightbar for control head installation and operation instruction.

OPTIONS & SPECIFICATIONS

Many options are available for the LED X 2100. This section is designed to describe the function of the various LED X 2100 options.

LED WARNING MODULES

WARNING!



This Product contains high intensity LED devices. To prevent eye damage, DO NOT stare into light beam at close range.

L.E.D. Fusing Considerations

Although the average current draw per module is very low, due to the type of circuit used to power each module the instantaneous peak current to a module can be significantly higher during low voltage conditions. To avoid prematurely blowing ATO style fuses or tripping breakers it is recommended the following rule-of-thumb be used to size fuses or breakers. This is especially important in lightbars with many LED modules running off a single fused source,

Minimum fuse size calculation:

1.5 x (number of modules being fused)

Example:

LED X 2100 Lightbar with 2 corner modules (2 per module) and 14 directional modules.

Minimum fuse requirement for single fuse - $1.5(2+2+14) = 27A$ minimum

Dim Operation

Lightbar LED modules are equipped with a low power "Dimming" mode. Dimming will be controlled by applying +12V by way of the appropriate wire(color) in the wire harness/wire list. When DIM is engaged the LED's will operate in a reduced power mode.

For safety purposes, the corner modules in lightbars are not connected to the dimming circuit. This ensures that when corner modules are turned on, full 360 degree coverage and compliance with SAE warning light standards is provided.

The DIM control wires(two white wires) located on each of the modules are connected from one module to the next. To disable the dimming function on a particular module, disconnect the white wires. Then reconnect the white wire to the white wire on another module that has dimming enabled.



WARNING!

The Dim setting reduces the light output of emergency warning lights reducing the effectiveness of them especially in brightly lit areas. Failure to use adequate light for the circumstances can cause motorists to fail to see the emergency vehicle and lead to serious personal injury or death. Never use the DIM setting in a brightly lit area. Use of the DIM setting may cause emergency lights to not comply with applicable emergency warning light standards. Use caution when using the DIM setting to assure that motorists can clearly see the emergency vehicle.

Code 3® OPTIX™ 360 DEGREE CORNER MODULES

The LED X™ 2100 Lightbar is equipped with new Code 3® OPTIX™ 360 degree corner LED modules that provide a full 360 degree of warning. The optic has been designed to exceed all applicable requirements for 360 degree warning devices in Red, Blue, Amber and White. The new OPTIX corner module is a (1" X 6") module and uses larger, higher efficiency, TIR optics to produce an enhanced corner signal over the existing (1" X 4") Code 3 LED X™ corner module. While the OPTIX will become the standard corner module for most configurations, the LED X corner module will still be available and may be required for some configurations. Installation and Operation for both modules will be the same. Consult the factory for further information.

Operating Specifications for 360 degree module:

Operating Voltage: 10-16 VDC, Reverse Polarity Protection
 Current Draw : Red/Amber - .5A avg @ 12.8 Volts
 Blue/White - .8A avg @ 12.8 Volts
 Available Colors - Red, Blue, Amber and White

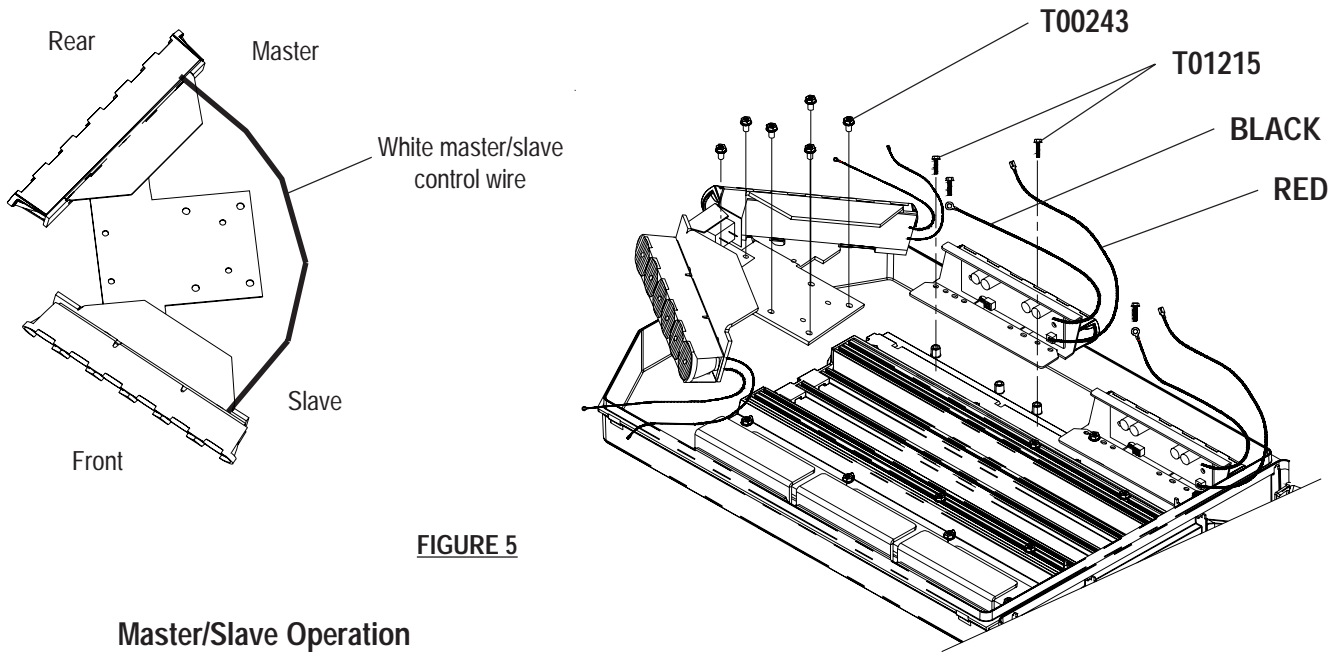

FIGURE 5

Master/Slave Operation

Each 360 degree corner module consists of a "master" and a "slave" driver circuit board, 360 degree optics and LED light engines along with a single integrated heatsink bracket.

The "master" circuit board (rear position) must always be powered for the "slave" (front position) to flash. The "master" is always located in the rear position of the module. The lightbar is wired to allow running only the rear facing LED on each module by removing power to the front facing "slave" module. This gives a "front-cutoff" function. The flash pattern for each corner pair can be selected by shorting together the 2-pin header J1, on the "master", momentarily and releasing. The module is set-up for "Cycleflash" as a standard. Holding down the 2-pin header for 5 sec., or longer, and releasing will return the pattern to Cycleflash. The following chart describes the available patterns and order;

360 Degree Module Flash Pattern - Table 1

See Figure 7, page 9, for jumper location.

Flash Pattern	Description
Cycle Flash	Cycles through various patterns @ 70 fpm
Five Flash	Five Pulses per flash @ 70 fpm
Quad Flash	Four Pulses per flash @ 70 fpm
NFPA	Four Pulses, 70% Duty Cycle @ 75 fpm
Triple Flash	Three Pulses per flash @ 70 fpm
Quad Pop Flash	Four Pulses per flash (3 equal, 1 extended) @ 70 fpm

Both heads will be in the mode selected. Both heads will flash together unless in Front Cut-off mode.

LED DIRECTIONAL MODULES

In addition to the 360 warning modules the lightbar may be equipped with a number of single head directional warning LED modules. These modules are available in either the existing LED X™ (1" X 4") or the new Code 3® OPTIX™ (1" X 6") and LC-LED directional modules in stationary and flashing versions (see figure 8). The stationary versions can be flashed by connecting the module(s) to any flasher that does not require ground through the load (example: Code 3® 700 series relay flasher). The flashing modules will have "Cycleflash" as the standard pattern. The OPTIX and LEDX flash pattern can be changed by shorting the 2-pin header, J1 as shown in Figure 7, momentarily then releasing. Table 2 shows the available patterns and the order when stepping through patterns. The module can be reset to "Cycleflash" by shorting the header for greater than 5 seconds and releasing. The LC-LED Modules flash patterns can be changed as described on page 9.

Operating Specifications for directional module:

Operating Voltage: 10-16 VDC, Reverse Polarity Protection

Current Draw : Flashing Module

Red/Amber - .25A avg @ 12.8 Volts

Blue/White - .4A avg @ 12.8 Volts

Steady Burn Module

Red/Amber - .5A avg @ 12.8 Volts

Blue/White - .8A avg @ 12.8 Volts

Available Colors - Red , Blue, Amber, and White

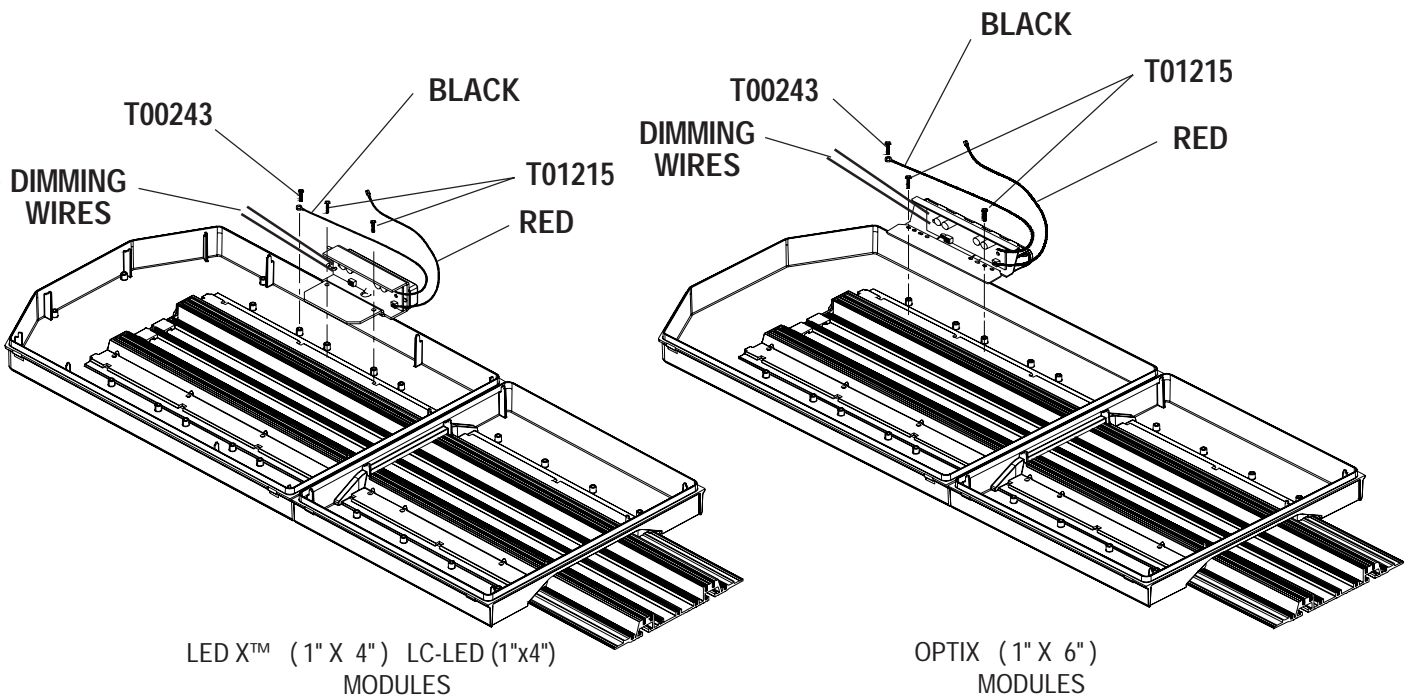
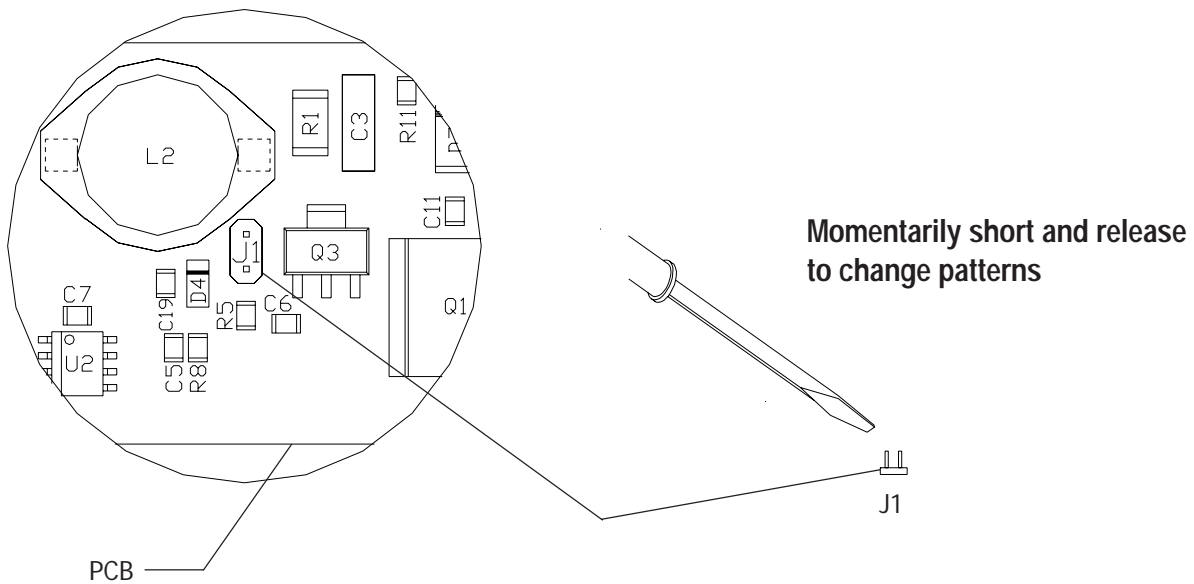

FIGURE 6

Directional module Flash Pattern - Table 2

Flash Pattern	Description
Cycle Flash	Cycles through various patterns @ 70 fpm
Steady-Burn	Steady-Burn
Five Flash	Five Pulses per flash @ 70 fpm
Quad Flash	Four Pulses per flash @ 70 fpm
Triple Flash	Three Pulses per flash @ 70 fpm
Double Flash	Two Pulses per flash @ 70 fpm
Fast Double Flash	Two Pulses per flash @ 85 fpm
NFPA	Four Pulses, 70% Duty Cycle @ 75 fpm
Quad Pop Flash	Four Pulses per flash (3 equal, 1 extended) @ 70 fpm
Triple Pop Flash	Three Pulses per flash (2 equal, 1 extended) @ 70 fpm
Double Pop Flash	Two Pulses per flash (1 equal, 1 extended) @ 70 fpm



Flash Pattern Header for OPTIX/LEDX

FIGURE 7

LC-LED MODULES

The LC-LED modules are equipped with one steady burn and three flashing patterns. To select a different flash pattern, apply +12 or +24 VDC to the red wire and connect the black wire to the power supply ground. The unit will flash in whatever pattern was last set. Change the pattern by momentarily touching the white wire to the power supply ground. The flash pattern will change to the next pattern according to the following list:

- Steady Burn
- 75 FPM Single
- 75 FPM Quad
- Cycle

Continue to cycle through the various patterns until the desired pattern is selected. The unit will retain this pattern even when power is removed. On Dual Color Modules, placing the yellow wire to ground will cause the amber LEDs to steady burn. Placing the black wire to ground will activate the non-amber LEDs. Most lightbars using Dual Color LCLED modules will be wired using a relay that allows power switching to activate the non-amber portion of the unit. **Note: The white flash pattern selection wire must be protected from contact with the system ground to prevent inadvertent changes to the flash pattern. This can be accomplished by sealing or capping the end of the wire.** Note: Regardless of the location in the program in the flash pattern list, the unit can be forced to steady burn by permanently electrically tying the white wire to the black wire. It is recommended that all heads be set to the desired pattern at a workbench prior to installation.

ALLEY LIGHTS - Located at the ends of the light bar to provide light to the side of the vehicle. The lamps used are a bayonet type or MR11 type.

STATIONARY LAMPS/TAKEDOWN LIGHTS - A stationary reflector assembly used for ArrowStik flashing, takedown, and/or work light applications. Lamps in these units are bayonet type or MR11 type and the units are mounted with two screws.

D.O.T. LIGHTS - A set of three marker lights as required by the Department of Transportation for truck application. Lamps are wedge base '194' type.

Maintenance

Lens Cleaning

Use plain water and a soft cloth, or Code 3® lens polish and a very soft paper towel or facial tissue. Because plastic scratches easily, cleaning is recommended only when necessary (about every six months). Do not subject the lenses to car washes that use brushes, as these will scratch the lenses.

Lens Removal

First, disengage the lens clips (4 per lens) as shown in Figure 9. Finally, insert a screwdriver into the small slot in the lens clip pocket or the lens edge, and twist the screwdriver to lift the lens.

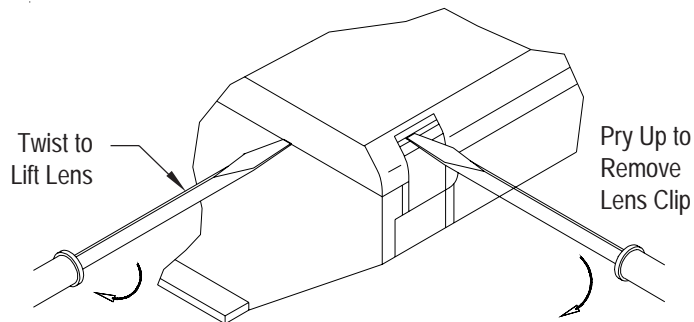

FIGURE 9

Changing Rotating Reflector Lamps

WARNING!



Lamps are extremely hot! Allow to cool completely before attempting to remove. Gloves and eye protection should be worn when handling halogen lamps as they are pressurized and accidental breakage can result in flying glass.

Remove the lens as outlined above. Next, inspect the lamp and refer to Figure 10 to replace the lamp.

Note: Make sure lamp is cool before attempting to change it. Also, when installing a new lamp, be sure not to touch the glass with fingers. If contact is made, clean the glass with a soft cloth after inspection.

If attempting to clean the reflector, use only a mild glass cleaner and a very soft cloth. Do not attempt to use any wax type products as these will burn onto the reflector.

Remove the reflector assembly by removing the appropriate fasteners, then remove the snap-on filter if necessary. In most cases, these lamps will be a bayonet style, so simply push in and turn counterclockwise to remove.

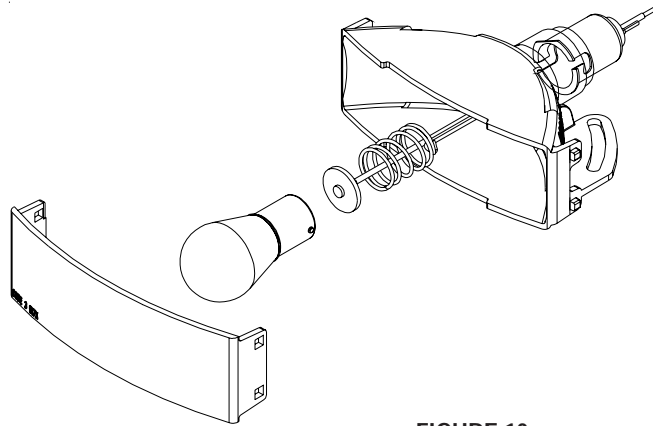
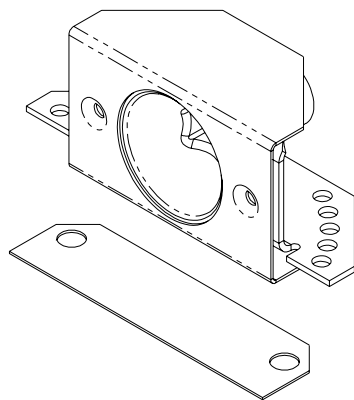

FIGURE 10

MR11 Style Assembly

For MR11 style takedown or alley light assemblies refer to Figure 11 for lamp replacement. Remove the lamp assembly by removing the appropriate fasteners, remove fasteners sandwiching MR11 in bracket, and remove lamp. Replace the lamp and reassemble.

Caution: Be sure to replace the heat shield gasket with the foil side up when reinstalling the takedown assemblies. Damage could occur without this gasket.



ALLEY ASSEMBLY for use with LED X™

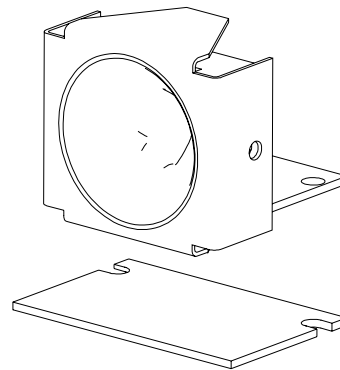

ALLEY ASSEMBLY for use with OPTIX™

FIGURE 11

LED X™ 2100 EXPLODED VIEW

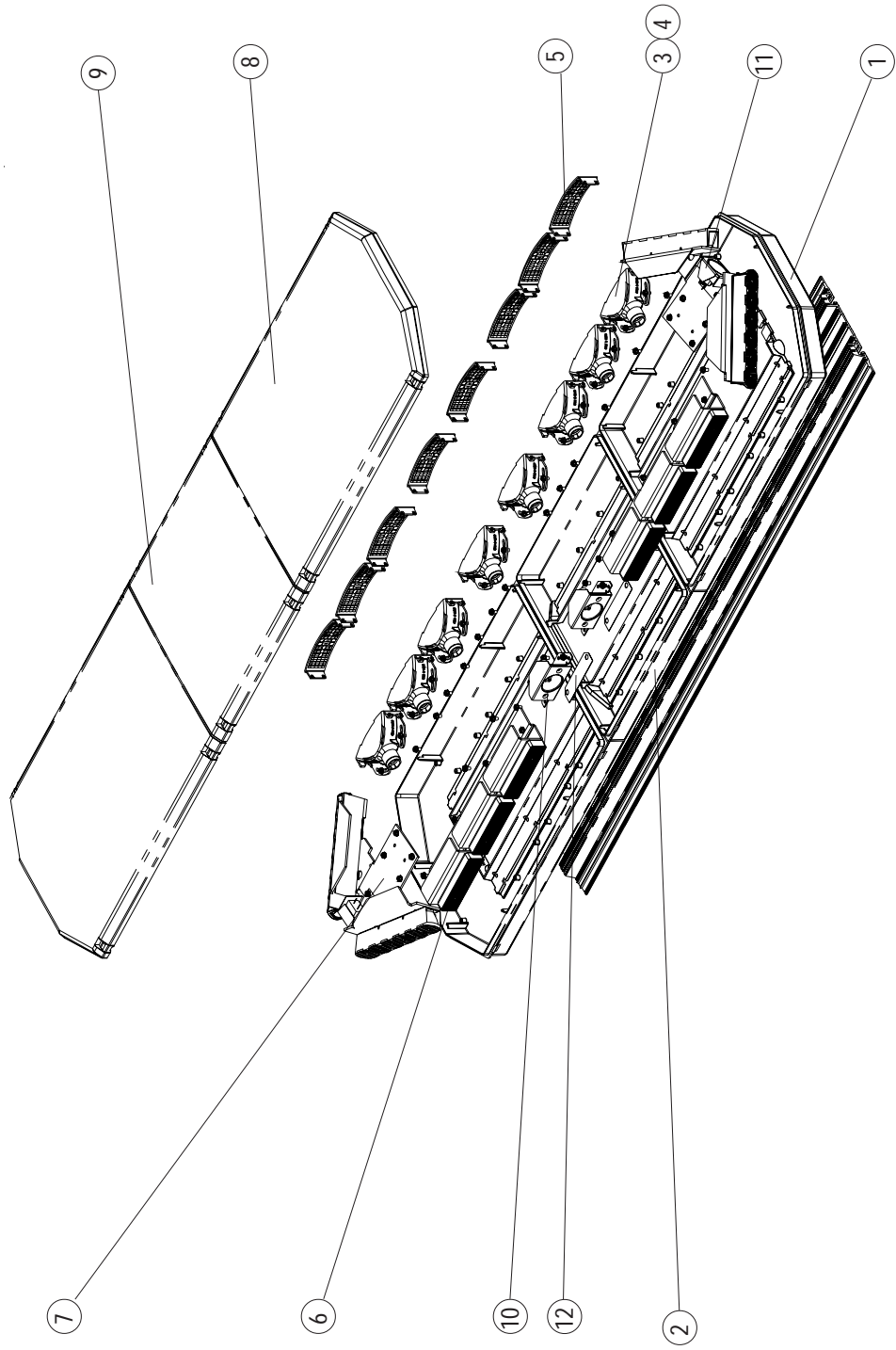

Note: All screws are part no. 1215 unless otherwise indicated

FIGURE 12

Parts List

(Reference numbers identify items shown in Figures on previous pages)

<u>Ref No.</u>	<u>Description</u>	<u>Part No.</u>
	#8 x .250" Sheet Metal Screw	T05029
	#8 x .270" Sheet Metal Screw	T01215
	#8 x .375" Sheet Metal Screw	T00243
	5/16" Cable Clamp	T00346
	1/2" Cable Clamp	T00903
	3/8" Cable Clamp	T00938
	S795 27W 12V Halogen Lamp	T05093
	S795 20W 12V Halogen Lamp	T05092
	1156 28W 12V Incandescent Lamp	T01538
	Lens Clip	T01777
	LED X™ 2100 22.5" Upper Beacon Lens (Clear)	T07971
	LED X™ 2100 22.5" Lower Beacon Lens (Clear)	T07961
	22.5" Upper Excalibur Lens (Clear)	T07951
	22.5" Upper Excalibur Lens (Red)	T07952
	22.5" Upper Excalibur Lens (Blue)	T07953
	22.5" Upper Excalibur Lens (Amber)	T07954
1	Bottom Outboard Lens - Clear	T02361
2	Bottom Center Lens - Clear	T02371
3	20W Halogen Stationary or alley Module	S50849M
	27W Halogen Stationary or alley Module	S50850M
	28W Incandescent Stationary or alley Module	S50851M
4	28W Incandescent Arrowstik Module	S50848M
5	Halogen Lower Light Head Filter	
	Green	T05170
	Clear	T05171
	Red	T05179
	Blue	T05173
	Amber	T05174
	External D.O.T. Strip Assembly	S50838M
6	LED flashing light head single	—
	Red	
	Blue	
	Amber	
	LED steady light head single	
	Red	
	Blue	
	Amber	
7	LED Corner light head dual Driver Side	
	Red	
	Blue	
	LED Corner light head dual Passenger Side	
	Red	
	Blue	
8	Outboard Lens Cap	—
	Clear	T03271
	Red	T03272
	Blue	T03273
	Amber	T03274
9	Center Lens Cap	
	Clear	T03281
	Red	T03282
	Blue	T03283
	Amber	T03284
10	MR11 35W Stationary Module	S51174M
11	MR11 35W Alley Module For LED X™	S95943M
	MR11 35W Alley Module For OPTIX™	S95289
12	MR11 Heat Shield For LED X	T03293
	MR11 Heat Shield For OPTIX	T07076

CALL FACTORY

Troubleshooting

All LED X™ 2100 Lightbars are thoroughly tested prior to shipment. However, should you encounter a problem during installation or during the life of the product, follow the guide below for information on repair and troubleshooting. Additional information may be obtained from the factory technical help line at 314-426-2700 ext. 2131.

Follow the guide below for information on repair and troubleshooting.

LED MODULE TROUBLESHOOTING GUIDE

Note: LED modules must be replaced as a module. There are no user serviceable parts.

PROBLEM	QUESTIONS	POSSIBLE CAUSE	SOLUTION
LED directional or 360 module not operating when powered.	Are both heads out on a 360 module, or is this a directional module? Yes No	a. Bad power/ground connection. b. Defective module. a. See next	a. Fix connection. b. Replace module.
360 corner module has one head out.	Is the rear head flashing and the front head out? Yes No	a. In front cut-off mode. Proper functioning. b. Check white wire between master/slave modules for damage or disconnection. c. Check power and ground of front module. a. See next	a. No problem b. Fix white wire/connection. c. Fix power/ground connection.
360 corner module has one head out.	Is the front head steady burning and the rear head out? Yes No	a. No power to master. Master(Rear) must be powered for slave(front) to operate. b. Failed master.	a. Check power/ground connections. b. Replace entire 360 module.
Dimming does not operate.	N/A	a. White wire on module not connected to source of +12V.	a. Connect white wire to +12V source.

Follow the guide below for information on repair and trouble shooting for the arrowstik option.

**ARROWSTIK® OPTION
TROUBLESHOOTING GUIDE**

PROBLEM	QUESTIONS	POSSIBLE CAUSE	SOLUTION
Arrowstik does not function when turned on.	Are the front panel LED indicators operating properly?		
	Yes	a. Check plug in rear of control box.	a. Reconnect plug.
	No	a. Check power and ground connections.	a. Reconnect ground/power.
Lamp or LED module does not come on when it should.	Are the front panel LED indicators functioning properly?		
	Yes	a. Bad lamp or defective LED module. b. Defective wiring connection.	a. Replace lamp or LED module. b. Repair connection.
	No	a. Control box is damaged.	c. Return to Code3.
Note: LED modules have no user serviceable parts. Replace entire module if found defective.			

Notes:

WARRANTY

Code 3[®], Inc.'s emergency devices are tested and found to be operational at the time of manufacture. Provided they are installed and operated in accordance with manufacturer's recommendations, Code 3[®], Inc. guarantees all parts and components except the lamps to a period of 1 year, LED Lighthouse modules to a period of 5 years (unless otherwise expressed) from the date of purchase or delivery, whichever is later. Units demonstrated to be defective within the warranty period will be repaired or replaced at the factory service center at no cost.

Use of lamp or other electrical load of a wattage higher than installed or recommended by the factory, or use of inappropriate or inadequate wiring or circuit protection causes this warranty to become void. Failure or destruction of the product resulting from abuse or unusual use and/or accidents is not covered by this warranty. Code 3[®], Inc. shall in no way be liable for other damages including consequential, indirect or special damages whether loss is due to negligence or breach of warranty.

CODE 3[®], INC. MAKES NO OTHER EXPRESS OR IMPLIED WARRANTY INCLUDING, WITHOUT LIMITATION, WARRANTIES OF FITNESS OR MERCHANTABILITY, WITH RESPECT TO THIS PRODUCT.

PRODUCT RETURNS

If a product must be returned for repair or replacement*, please contact our factory to obtain a Return Goods Authorization Number (RGA number) before you ship the product to Code 3[®], Inc. Write the RGA number clearly on the package near the mailing label. Be sure you use sufficient packing materials to avoid damage to the product being returned while in transit.

*Code 3[®], Inc. reserves the right to repair or replace at its discretion. Code 3[®], Inc. assumes no responsibility or liability for expenses incurred for the removal and /or reinstallation of products requiring service and/or repair.; nor for the packaging, handling, and shipping; nor for the handling of products returned to sender after the service has been rendered.

Public Safety Equipment, Inc.
10986 N. Warson Road
St. Louis, Missouri 63114-2029—USA
Ph. (314) 426-2700 Fax (314) 426-1337
www.code3pse.com

Code 3, [®]Inc., a subsidiary of
Public Safety Equipment, Inc.

Revision 9, 7/05 - Instruction Book Part No. T09453
©2002 Public Safety Equipment, Inc. Printed in USA