

# INSTALLATION & OPERATION MANUAL



FOR CODE 360®  
LIGHTBARS  
PATENT PENDING

Code 3,® Inc., a subsidiary of  
Public Safety Equipment, Inc.



# CODE 360®

## TRI-LEVEL LIGHT BAR

### CONTENTS:

Introduction.....	2-3
Unpacking & Pre-Installation.....	4
Installation & Mounting.....	4-6
Wiring Instructions.....	6-7
Options & Specifications.....	7-12
Maintenance.....	12-16
Parts List (Replacement Parts / Exploded View).....	17-20
Trouble Shooting.....	21-22
Notes.....	22-23
Warranty.....	24

For future reference record your lightbar's serial no. here \_\_\_\_\_

**IMPORTANT:**

*Read all instructions and warnings before installing and using.*

**INSTALLER:** *This manual must be delivered to the end user of this equipment.*

# Introduction

## The Code 360<sup>®</sup> Light Bar from Code 3<sup>®</sup>

### 360 Degrees of Light, the Nth Degree of Protection!

Check out all the exciting features of your new Code 360<sup>®</sup> light bar:

- ✓ Three levels and **four** rows of lights
- ✓ 360 degrees of coverage
- ✓ Outstanding safety features available including:
  - ✓ Alley lights
  - ✓ ArrowStik<sup>®</sup>
  - ✓ Oscilaser<sup>™</sup>
  - ✓ Tactical Takedowns<sup>™</sup>
- ✓ Corner pods allow forward positioning of:
  - ✓ X-Fire upper- and lower-level strobes
  - ✓ X-Sweep dual halogen intersection lights
- ✓ Available in:
  - ✓ All Strobe
  - ✓ All Halogen
  - ✓ Strobe/Halogen combination
- ✓ Can accommodate up to 10 locations for stationery lights

**Code 360<sup>®</sup> Quality Assurance** means that each light bar has been individually tested and approved



### WARNING!

The use of this or any warning device does not ensure that all drivers can or will observe or react to an emergency warning signal. Never take the right-of-way for granted. It is your responsibility to be sure you can proceed safely before entering an intersection, driving against traffic, responding at a high rate of speed, or walking on or around traffic lanes.

The effectiveness of this warning device is highly dependent upon correct mounting and wiring. Read and follow the manufacturer's instructions before installing or using this device. The vehicle operator should insure daily that all features of the device operate correctly. In use, the vehicle operator should insure the projection of the warning signal is not blocked by vehicle components (i.e.: open trunks or compartment doors), people, vehicles, or other obstructions.

This equipment is intended for use by authorized personnel only. It is the user's responsibility to understand and obey all laws regarding emergency warning devices. The user should check all applicable city, state and federal laws and regulations.

Public Safety Equipment, Inc., assumes no liability for any loss resulting from the use of this warning device.



**WARNING!**

Proper installation is vital to the performance of this warning device and the safe operation of the emergency vehicle. It is important to recognize that the operator of the emergency vehicle is under psychological and physiological stress caused by the emergency situation. The warning device should be installed in such a manner as to: A) Not reduce the output performance of the system, B) Place the controls within convenient reach of the operator so that he can operate the system without losing eye contact with the roadway.

Emergency warning devices often require high electrical voltages and/or currents. Properly protect and use caution around live electrical connections. Grounding or shorting of electrical connections can cause high current arcing, which can cause personal injury and/or severe vehicle damage, including fire.

PROPER INSTALLATION COMBINED WITH OPERATOR TRAINING IN THE PROPER USE OF EMERGENCY WARNING DEVICES IS ESSENTIAL TO INSURE THE SAFETY OF EMERGENCY PERSONNEL AND THE PUBLIC.

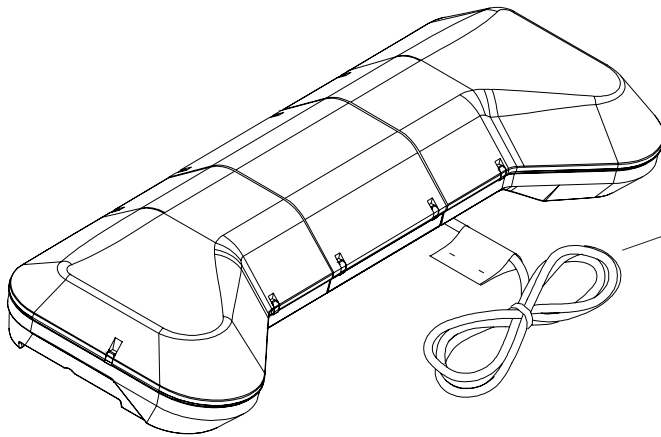

Wiring Instructions (read Carefully Before Installation)

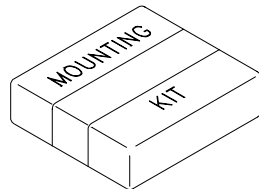

# Unpacking & Pre-installation

Carefully remove the light bar and place it on a flat surface, taking care not to scratch the lenses or damage the cable coming out of the bottom. Examine the unit for transit damage, broken lamps, etc. Report any damage to the carrier and keep the shipping carton.

Standard light bars are built to operate on 12 volt D.C. negative ground (earth) vehicles. If you have an electrical system other than 12 volt D.C. negative ground (earth), and have not ordered a specially wired light bar, contact the factory for instructions.

Test the unit before installation. To test, touch the black wire to a negative ground (earth) and the other wires to +12 volts D.C., in accordance with the instructions attached to the cable (an automotive battery is preferable for this test). A battery charger may be used, but please note that some electronic options (flashers, stingrays, etc.) may not operate normally when powered by a battery charger. If problems occur at this point, contact the factory.

# Installation & Mounting

**WARNING!**



Utilizing non-factory supplied screws and/or mounting brackets and/or the improper number of screws may result in loss of warranty coverage on the equipment.

**MOUNTING HARDWARE** - All mounting hardware is packed in a small box inside the main carton. Four standard kits are available: (1) Hook-On Type, (1) Tow and Recovery and (2) Permanent Types. These are discussed in detail later. **Note:** Hook-on mounting for "gutterless" type vehicles will require a special hook for mounting. Several special application hooks are available. Contact the factory for details.

## Hook-on Mounting

Begin the installation by attaching the rubber feet to the mounting brackets with 3/8" long Flat Head Screw and Nylock nuts. See Figure 1. Place the light bar upside down on a table or other work surface, being careful not to scratch the lenses. Slide the 5/16" carriage bolts into the frame. Secure the mounting brackets finger tight so they support the weight of the light bar, but still are positionable. Now would be a good time to insert the 3 1/2" long carriage bolt through the mounting brackets. If desired, you can also unbundle the lightbar cable and feed it through the drivers' side mounting bracket. Locate the vehicle on a level surface. Place the lightbar on the roof of the vehicle. Place a soft pad in the center of the roof to protect the paint. The mounting brackets must be placed so that the rubber feet are resting on the curved section of the roof, see Figure 2. This is the strongest part of the roof. If necessary bend the mounting bracket feet to match the contour of roof. Once the light bar is centered, tighten the mounting bracket to the light bar. Using a tape measure and a level, center the light bar from side to side and locate a position on the roof where the light bar is level. Black nylon spacers are provided to level lightbar. Place spacer between rubber foot and mounting bracket and use longer flat head screws provided to secure foot to bracket.

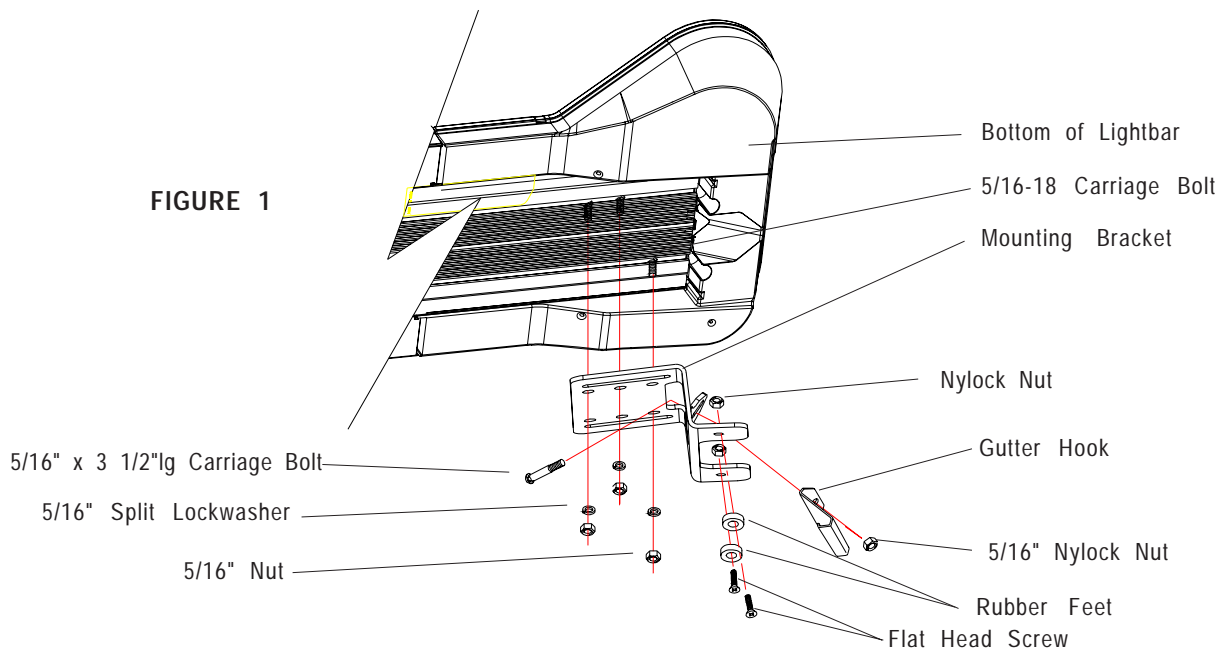

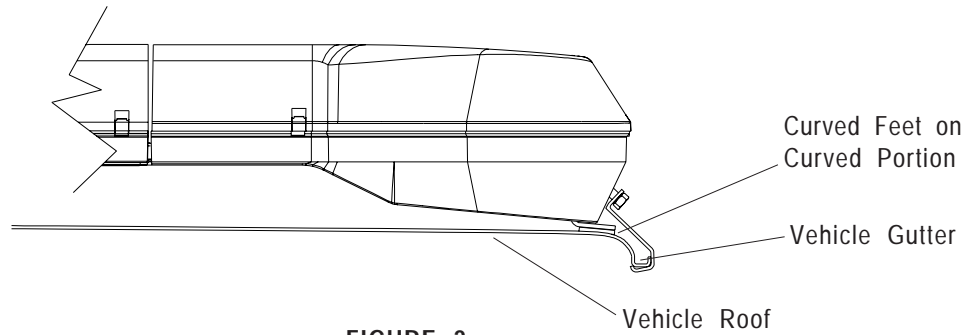

**FIGURE 2**

Insert the carriage bolts through the holes in the gutter hooks, and into a 5/16" Nylock nut as shown in Figure 1. If a special hook for a "gutterless" vehicle is used, refer to the instructions for that hook at this time. The carriage bolt provided is sized for the most common installations, but longer and shorter bolts are available at any hardware store. Tighten the nuts onto the carriage bolts on both sides evenly keeping the light bar centered and level.

**NOTE:** Tighten only until the bar is secure (bar does not move when bumped sharply with the heel of the palm). It is NOT necessary to dimple the roof to obtain a stable attachment. If the light bar "bows" more than 3/16" (determined by placing a straightedge along the front, bottom part of the frame and measuring downward at the center of the frame), loosen the 5/16" trim nut slightly.

## Permanent Mounting

**Typical Mounting:** Refer to Figure 3. Place the light bar upside down on a table or other work surface, being careful not to scratch the lenses. Slide the 5/16" carriage bolts into the frame. Secure the mounting brackets finger tight so they support the weight of the light bar. Place the unit on the roof of the vehicle. Place a soft pad in the center of the roof to protect the paint. The mounting brackets must be placed so that they are resting on the curved section of the roof, see Figure 4. This is the strongest part of the roof. Once the light bar is centered, tighten mounting brackets to light bar. Using a tape measure and a level, center the light bar from side to side and locate a position of the roof where the light bar is level. The shims provided may be used here to help level the light bar. Also, the tabs on the mounting bracket may be bent at any angle to match the curvature of the roof (see Figure 4).

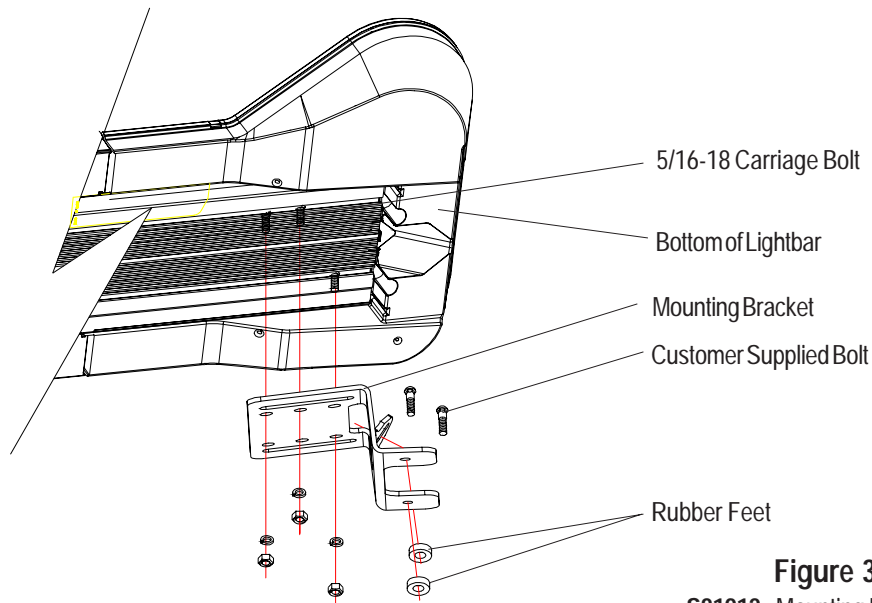

**Figure 3**  
**S81912 - Mounting Kit without**  
**Adaptor Bracket**

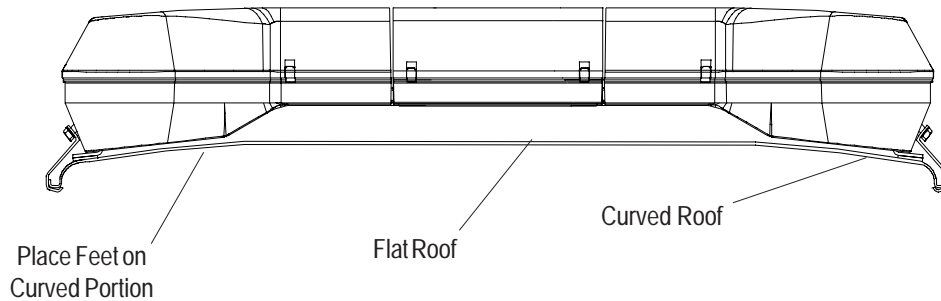

FIGURE 4

Once the light bar is level and centered, mark the holes through the mounting tabs and remove the light bar from the vehicle. Make sure that the drill will not damage anything when penetrating the roof. Drill the mounting holes and remove any burrs. Attachment can be made using 1/4" cap screws, toggle bolts, or other fasteners as may be convenient. Use sealant as necessary to prevent water leakage into the vehicle.

## Wiring Instructions



### WARNING!

Larger wires and tight connections will provide longer service life for components. For high current wires it is highly recommended that terminal blocks or soldered connections be used with shrink tubing to protect the connections. Do not use insulation displacement connectors (e.g. 3M<sup>®</sup> Scotchlock type connectors). Route wiring using grommets and sealant when passing through compartment walls. Minimize the number of splices to reduce voltage drop. High ambient temperatures (e.g. underhood) will significantly reduce the current carrying capacity of wires, fuses, and circuit breakers. Use "SXL" type wire in engine compartment. All wiring should conform to the minimum wire size and other recommendations of the manufacturer and be protected from moving parts and hot surfaces. Looms, grommets, cable ties, and similar installation hardware should be used to anchor and protect all wiring. Fuses or circuit breakers should be located as close to the power takeoff points as possible and properly sized to protect the wiring and devices. Particular attention should be paid to the location and method of making electrical connections and splices to protect these points from corrosion and loss of conductivity. Ground terminations should only be made to substantial chassis components, preferably directly to the vehicle battery. The user should install a fuse sized to approximately 125% of the maximum Amp capacity in the supply line to protect against short circuits. For example, a 30 Amp fuse should carry a maximum of 24 Amps. **DO NOT USE 1/4" DIAMETER GLASS FUSES AS THEY ARE NOT SUITABLE FOR CONTINUOUS DUTY IN SIZES ABOVE 15 AMPS.** Circuit breakers are very sensitive to high temperatures and will "false trip" when mounted in hot environments or operated close to their capacity.

Before attempting to connect wiring refer to wire tag attached to the lightbar's main cable. Each wire in the cable controls a separate lightbar function as described in the wire tag.

The only significant difference between the CODE 360<sup>®</sup> with optional ArrowStik<sup>®</sup> and a conventional CODE 360, is the additional, thinner cable exiting the bottom of the lightbar. The larger cable is the lightbar power cable. Route the wiring cable into the engine or passenger compartment, taking care to use grommets and to apply sealant around openings to keep water out. It is advisable to leave an extra loop of cable when installing the light bar to allow for future changes or reinstallations. Connect the black lead to a solid frame ground (earth), preferably, the (-) or ground (earth) side of the battery and bring the other wires to the control head or switches. Connect the wires as directed by the wiring instructions on the cable.

# Arrowstik® / Narrowstik®

OPTIONAL HALOGEN ARROWSTIK® (7-wire) / L.E.D. NARROWSTIK® (11-wire) WIRING AND CONTROL HEAD INSTALLATION - After installation of the lightbar, route the smaller of the two power cables through the vehicle to the location chosen for the control head. Cut the cable to length and strip back the outer insulation to expose the seven or eleven colored wires. Strip back 1/8" - 1/4" of colored insulation from each of the wires in the cable. Connect these wires to the seven position / eleven position terminal plug enclosed in the user parts bag, according to the diagram on the bottom of the control head.

- Refer to the control head manual packaged with the lightbar for control head installation and operation instruction.

**OPTIONAL STROBE WIRING INSTRUCTIONS** - For all configurations the strobe power supply(s) will be powered by the #14 AWG Red and Red/Black wires in the lightbar main cable. For 2 or 4 head configurations only the Red or Red/Black wire will be utilized. For 6, 8, 10 and 12 head configurations both wires will be utilized. These wires will supply DC power to each strobe power supply(s) so all user supplied switches and wiring connected to the Red and/or Red/Black wires should be rated for a minimum of 10 Amps and fused at a maximum of 15 Amps, for each wire used. Two additional wires in the main cable (typically Green and Green/Black) are used to control the flash mode of the power supply. These wires are low current connections at typically less than 1 Amp. (See lightbar "wire tag" for wire color).

## OPTIONS & SPECIFICATIONS

Many options are available for the LED X 2100. This section is designed to describe the function of the various LED X 2100 options.

### LED WARNING MODULES

#### L.E.D. Fusing Considerations

Although the average current draw per module is very low, due to the type of circuit used to power each module the instantaneous peak current to a module can be significantly higher during low voltage conditions. To avoid prematurely blowing ATO style fuses or tripping breakers it is recommended the following rule-of-thumb be used to size fuses or breakers. This is especially important in lightbars with many LED modules running off a single fused source wire,

#### **Minimum fuse size calculation:**

1.5 x (number of modules being fused)

Example:

Excalibur Lightbar with 2 corner modules (2 per module) and 4 directional modules.

Minimum fuse requirement for single fuse -  $1.5(2+2+4) = 10A$  minimum

**WARNING!**



This Product contains high intensity LED devices. To prevent eye damage, DO NOT stare into light beam at close range.

## Dim Operation

Lightbar LED modules are equipped with a low power "Dimming" mode as standard. Dimming will be controlled by applying +12V by way of the appropriate wire(color) in the wire harness/wire list. When DIM is engaged the LED's will operate in a reduced power mode.

For safety purposes, the corner modules in lightbars are not connected to the dimming circuit. This ensures that when corner modules are turned on, full 360 degree coverage and compliance with SAE warning light standards is provided.

The DIM control wires(two white wires) located on each of the modules are connected from one module to the next. To disable the dimming function on a particular module, disconnect the white wires. Then reconnect the white wire to the white wire on another module that has dimming enabled.



### **WARNING!**

The Dim setting reduces the light output of emergency warning lights reducing the effectiveness of them especially in brightly lit areas. Failure to use adequate light for the circumstances can cause motorists to fail to see the emergency vehicle and lead to serious personal injury or death. Never use the DIM setting in a brightly lit area. Use of the DIM setting may cause emergency lights to not comply with applicable emergency warning light standards. Use caution when using the DIM setting to assure that motorists can clearly see the emergency vehicle.

## Code 3® OPTIX™ 360 DEGREE CORNER MODULES

The Code360™ Lightbar may be equipped with Code 3® OPTIX™ 360 degree corner LED modules that provide a full 360 degree of warning. The optic has been designed to exceed all applicable requirements for 360 degree warning devices in Red, Blue, and Amber. The new OPTIX corner module is a ( 1" X 6" ) module and uses larger, higher efficiency, TIR optics to produce an enhanced corner signal over the existing ( 1" X 4" ) Code 3 LED X™ corner module. While the OPTIX will become the standard corner module for most configurations, the LED X corner module will still be available and may be required for some configurations. Installation and Operation for both modules will be the same. Consult the factory for further information.

### **Operating Specifications for 360 degree module:**

Operating Voltage: 10-16 VDC, Reverse Polarity Protection  
Current Draw :     Red/Amber - .5A avg @ 12.8 Volts  
                          Blue/White    - .8A avg @ 12.8 Volts  
Available Colors - Red, Blue, Amber and White

## Master/Slave Operation

Each 360 degree corner module consists of a "master" and a "slave" driver circuit board, 360 degree optics and LED light engines along with a single integrated heatsink bracket.

The "master" circuit board (rear position) must always be powered for the "slave" (front position) to flash. The "master" is always located in the rear position of the module. The lightbar is wired to allow running only the rear facing LED on each module by removing power to the front facing "slave" module. This gives a "front-cutoff" function. The flash pattern for each corner pair can be selected by shorting together the 2-pin header J1, on the "master", momentarily and releasing. The module is set-up for "Cycleflash" as a standard. Holding down the 2-pin header for 5 sec., or longer, and releasing will return the pattern to Cycleflash. The following chart describes the available patterns and order;

**360 Degree Module Flash Pattern - Table 1**

See Figure 5, page 10, for header location.

Flash Pattern	Description
Cycle Flash	Cycles through various patterns @ 70 fpm
Five Flash	Five Pulses per flash @ 70 fpm
Quad Flash	Four Pulses per flash @ 70 fpm
NFPA	Four Pulses, 70% Duty Cycle @ 75 fpm
Triple Flash	Three Pulses per flash @ 70 fpm
Quad Pop Flash	Four Pulses per flash ( 3 equal, 1 extended) @ 70 fpm

Both heads will be in the mode selected. Both heads will flash together unless in Front Cut-off mode.

## LED DIRECTIONAL MODULES

In addition to the 360 warning modules the lightbar may be equipped with a number of single head directional warning LED modules. These modules are available in either the existing LED X™ ( 1" X 4" ) or the new Code 3® OPTIX™ ( 1" X 6" ) and LC-LED directional modules in stationary and flashing versions ( see figure 8). The stationary versions can be flashed by connecting the module(s) to any flasher that does not require ground through the load (example: Code 3® 700 series relay flasher). The flashing modules will have "Cycleflash" as the standard pattern. The OPTIX and LEDX flash pattern can be changed by shorting the 2-pin header, J1 as shown in Figure 5, momentarily then releasing. Table 2 shows the available patterns and the order when stepping through patterns. The module can be reset to "Cycleflash" by shorting the header for greater than 5 sec. and releasing.

### Operating Specifications for directional module:

**Operating Voltage:** 10-16 VDC, Reverse Polarity Protection

**Current Draw :** Flashing Module

Red/Amber - .25A avg @ 12.8 Volts

Blue/White - .4A avg @ 12.8 Volts

Steady Burn Module

Red/Amber - .5A avg @ 12.8 Volts

Blue/White - .8A avg @ 12.8 Volts

**Available Colors** - Red , Blue, Amber, and White

**Directional module Flash Pattern - Table 2**

Flash Pattern	Description
Cycle Flash	Cycles through various patterns @ 70 fpm
Steady-Burn	Steady-Burn
Five Flash	Five Pulses per flash @ 70 fpm
Quad Flash	Four Pulses per flash @ 70 fpm
Triple Flash	Three Pulses per flash @ 70 fpm
Double Flash	Two Pulses per flash @ 70 fpm
Fast Double Flash	Two Pulses per flash @ 85 fpm
NFPA	Four Pulses, 70% Duty Cycle @ 75 fpm
Quad Pop Flash	Four Pulses per flash ( 3 equal, 1 extended) @ 70 fpm
Triple Pop Flash	Three Pulses per flash ( 2 equal, 1 extended) @ 70 fpm
Double Pop Flash	Two Pulses per flash ( 1 equal, 1 extended) @ 70 fpm

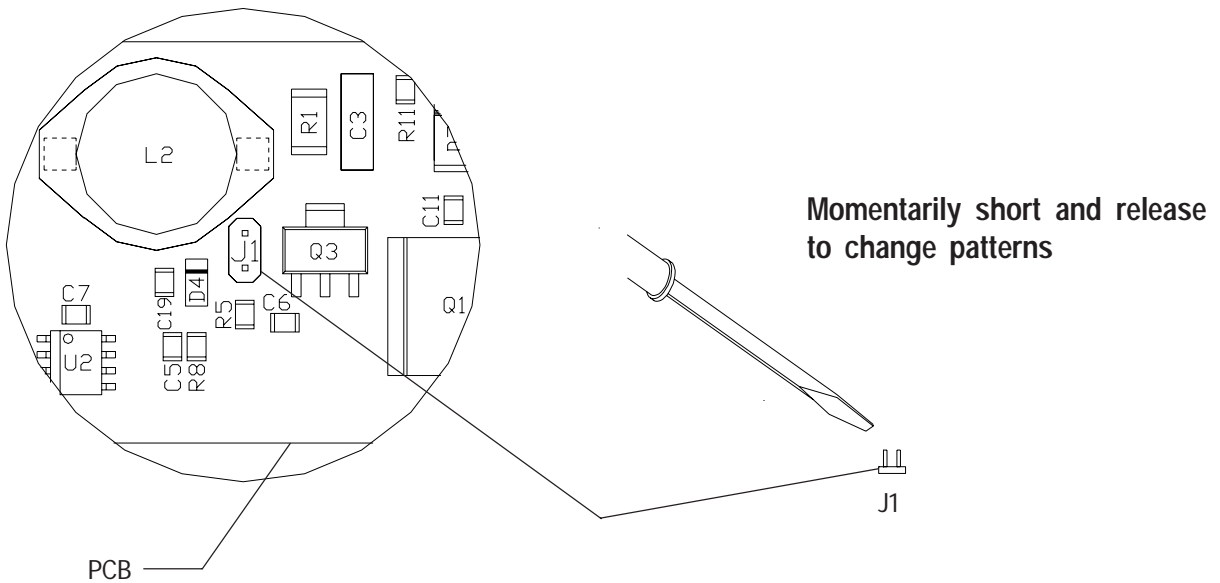

**Flash Pattern Header for OPTIX/LEDX**

**FIGURE 5**

## STROBE CONNECTIONS

### POWER CONNECTION

For all configurations the strobe power supply(s) will be powered by the #16AWG RED, and/or RED/BLK wires. For 2 or 4 head configurations, one wire will be used, 6, 8, 10 and 12 head configurations will use two wires. These wires supply power to each strobe power supply. All user switches and wiring connected to the RED, RED/BLK and or RED/WHT wires must be rated for a **minimum of 10 Amps** and fused at a **maximum of 15 Amps** for each wire used.

**Flash Patterns** - All power supplies offer "Quad Flash" and "Random Flash". The flash patterns are controlled by jumpers on the power supply and can be changed by first removing the power supply from the lightbar and then setting the jumpers. Refer to the following tables:

Jumper	Quad	Random
J9	2 - 3	1 - 2
J36	2 - 3	2 - 3

Jumper	Quad	Random
J31	2 - 3	1 - 2

	Quad	Random
YELLOW	N/C	+12

### Rear Only Flash Pattern

Connect the RED and/or RED/BLK wire in the 16 wire cable to +12 VDC through a user supplied switch.

**4/6 Head:** Rear inboard and outboard strobes on each side will flash at a minimum rate of 70 FPM (flashes per minute).

**2 Head:** If front or rear inboard strobes are present, strobes will flash at a minimum rate of 70 FPM.

### Alternating Flash Pattern

Connect the RED and/or RED/BLK wire and GREEN wire in the 16 wire cable to +12 VDC through a user supplied switch. This mode overrides **REAR ONLY MODE**.

**4/6 Head:** Front and Rear inboard and outboard strobes on each side will flash at a minimum rate of 70 FPM (flashes per minute).

**2 Head:** Front or rear inboard strobes will flash at a minimum rate of 70 FPM.

### Pursuit Flash Pattern

Connect the RED and/or RED/BLK wire and GREEN/BLACK wire in the 16 wire cable to +12 VDC through a user supplied switch. This mode overrides **ALL OTHER MODES**.

**4/6 Head:** Front inboard and outboard strobes on each side will flash at a minimum rate of 70 FPM.

**2 Head:** If front inboard strobes are present, strobes will flash minimum at a rate of 70 FPM.

**INTERSECTION LIGHTS** - A high intensity 120° oscillator, located in the lower outboard corner of the light bar. Maintenance of these units is much the same as for a typical rotator. Two mounting screws hold the assembly in place. **Caution: Never install a black worm on the 120° Intersection Light.**

**X-SWEEP** - Dual halogen intersection lights, mounted one above the other on a common bracket, located in the lower outboard corners of the lightbar.

**X-FIRE** - Upper and lower-level strobes, mounted one above the other, 90 degrees to one another, located in the outboard corners of the lightbar.

**ALLEY LIGHTS** - Located in the mid section of the light bar at each end, to provide light to the side of the vehicle. The lamps used are a bayonet type. The mounting bracket and reflector are adjustable to allow aiming the unit.

**HIGH SPEED ROTATOR** - A rotator that produces twice as many flashes as a conventional assembly. Maintenance is the same as for a typical rotator.

**Multi-Functional Control Module** - Using standard lighting controls the operator can select the operation of the Intersection Lighthouse assemblies.

**STATIONARY LAMPS/TAKEDOWN LIGHTS** - A stationary reflector assembly used for ArrowStik® flashing, takedown, and/or work light applications. These are located in the lower section of the light bar. Lamps in these units are bayonet type and the units are mounted with two screws.

**STOP/TURN/TAIL LIGHTS** - Located in the upper section of the light bar facing rear, one on the driver side, one on the passenger side, these lights provide stop, turn and tail signals to following traffic when connected to the vehicle lighting system. Lamps used are an 1157 bayonet type.

**D.O.T. LIGHTS** - A set of three marker lights as required by the Department of Transportation for truck application. Lamps are wedge base '194' type.

**OSCILASER™** - This is a highly effective warning light that features a constant 35 watt halogen signal that covers every area within its field of illumination at least once per second. It has an up and down as well as a side to side signal. Maintenance for these units is much the same as a typical rotator. The lamps used are bayonet type. This unit is located in the upper center section and/or in the center position in the outboard sections of the light bar.

**TACTICAL TAKEDOWN™ LIGHTS** - A Flashing or steady burn takedown light that moves at a 15 degree angle when activated. Available in front and rear corners of lightbar.

## Maintenance

### Lens Cleaning

Use plain water and a soft cloth, or Code 3® lens polish and a very soft paper towel or facial tissue. Because plastic scratches easily, cleaning is recommended only when necessary (about every six months). Do not subject the lenses to car washes that use brushes, as these will scratch the lenses.

### Lens Removal

First, disengage the lens clips

(4 per lens) as shown in Figure 6. Finally, insert a screwdriver into the inside edge or corner of the lens, and twist the screwdriver to lift the lens.

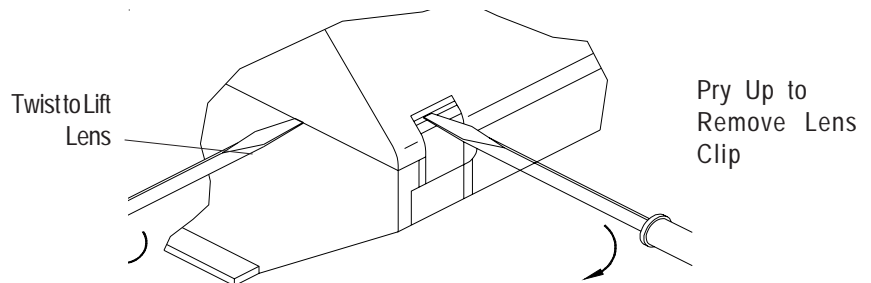

Changing Rotating Reflector Lamps

Figure 6

## WARNING!



Lamps are extremely hot! Allow to cool completely before attempting to remove. Gloves and eye protection should be worn when handling halogen lamps as they are pressurized and accidental breakage can result in flying glass.

Remove the lens as outlined above. Next, inspect the lamp and compare to Figure 7 to determine lamp type. It may be necessary to remove any rotating or cylindrical filters to make access easier. Note: Make sure lamp is cool before attempting to change it. Also, when installing a new lamp, be sure not to touch the glass with fingers. If contact is made, clean the glass with a soft cloth after inspection.

**H-1: Style.** First grasp lamp at base and turn until retaining clip tab is accessible. Using a blade screwdriver, remove retaining clip and pull lamp straight up. Replace with new lamp. Insure that the power lead and retaining clip is fully seated. (See figure 7)

The following are optional features that may or may not be included in your control head depending upon which model you purchased.

**"Fast Speed" Mode:** Fast speed and Dim Modes are combined. Pushing the button marked "Fast" will cause each of the 4 patterns of the ArrowStik to operate at a faster rate, with the same amount of light intensity.

**"Dim" Mode:** Dim and Fast speed Modes are combined. Pushing the button marked "Dim" will cause each of the 4 patterns of the ArrowStik to operate at a lower intensity level. This is for use at night when 100% intensity is too much, or daytime when current draw needs to be reduced.

**Bayonet Style:** Push down and turn to remove lamp. Install a new lamp the same way. (SEE FIGURE 7)

**Note:** If attempting to clean the reflector, use only a mild glass cleaner and a very soft cloth. Do not attempt to use any wax type products as these will burn onto the reflector.

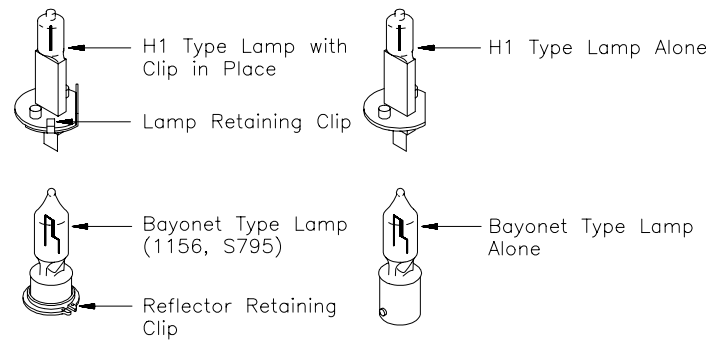

Figure 7

### Changing Lower Unit Lamp and/or Filter

Refer to Figure 10. Remove the reflector assembly by removing the appropriate fasteners, then remove the snap-on filter if necessary. In most cases, these lamps will be a bayonet style, so simply push in and turn counterclockwise to remove.

### Replacement for Upper and Lower Level Components

See exploded view "Parts Section" for fastener removal, component location, and assembly configuration. **Caution, extreme care must be taken when installing components to prevent pinching wire connections and to avoid interference with moving assemblies.**



High voltages and/or temperatures are present inside the unit. Disconnect from power and wait 10 minutes prior to servicing or troubleshooting. Use hand and eye protection when changing halogen lamps or flashtubes.

### Strobe Filter Replacement

Refer to figure 8. The filter can be removed by unsnapping it from the light head and by removing the mirror if present for clearance. Prying the filter from the front may damage the glass strobe tube or reflector.

To replace the filter, reverse the above procedure. The filter should be fully engaged on the light head assembly. Care should be taken to not damage the strobe tube or to scratch the reflective surface of the reflector when replacing the filter.

### Strobe Light Head Replacement

Refer to figure 8. Disconnect the light head assembly wiring from the strobe power supply and remove the filter if any. Unfasten the screws attaching the light head mounting bracket to the light bar chassis and remove the light head from the light bar. On a bench or other work suitable work surface unfasten the screws attaching the strobe light head assembly from the light head mounting bracket. Install the new strobe light head assembly to the light head mounting bracket and reinstall the light head back onto the light bar chassis. Reconnect the light head wiring to the strobe power supply and reattach the filter. It is important to reroute and secure the wiring as close as possible to its original position.

**Caution, verify that no wires are interfering with the operation of the fan located at the end of the power supply.**

## Electronics Module Removal

In the event that the power supply or a strobe lamp assembly must be returned to the factory for service, mark each wire with a tag to identify each function and note the proper location before disconnecting the wiring. Figure 9 can be used to mark the locations of the individual connections as well.

Refer to Figure 9 for power supply removal. Remove the four (4) screws holding the power supply. Disconnect the wire leads, and move the power supply to the side. Remove the 2 screws holding the capacitor assembly and lift the strobe power supply/capacitor assembly from the lightbar as a unit. To reinstall the power supply reverse the above steps.

**Caution:** Verify that wires are not pinched or damaged when reinstalling power supply.

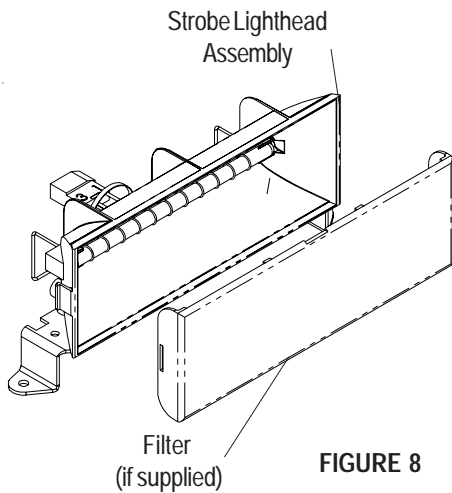
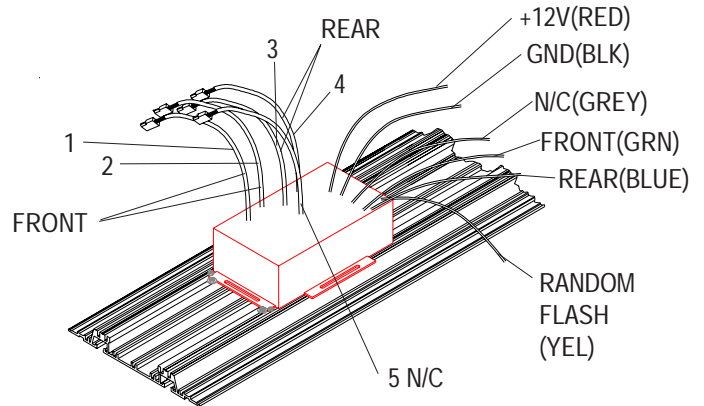

FIGURE 8



PSE 490E  
FIGURE 10A

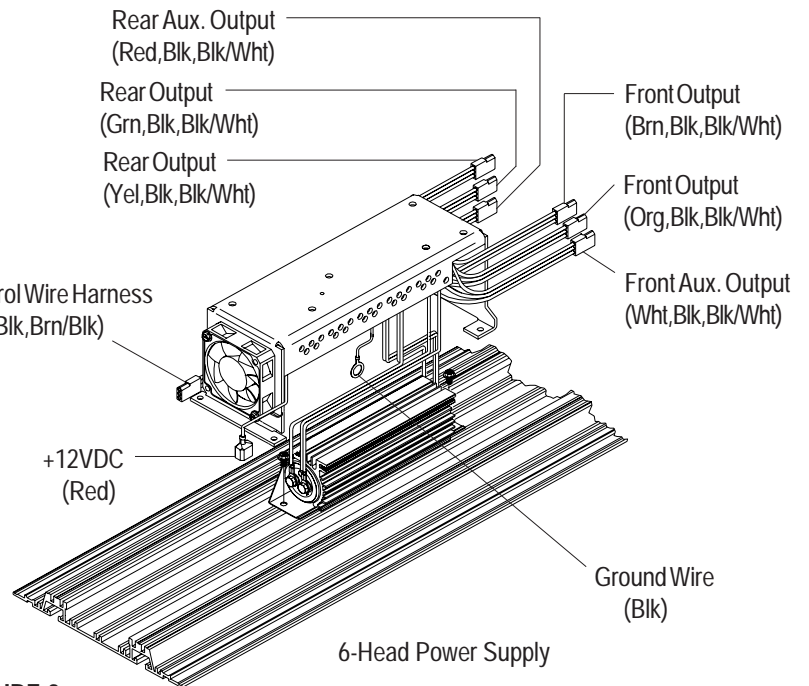
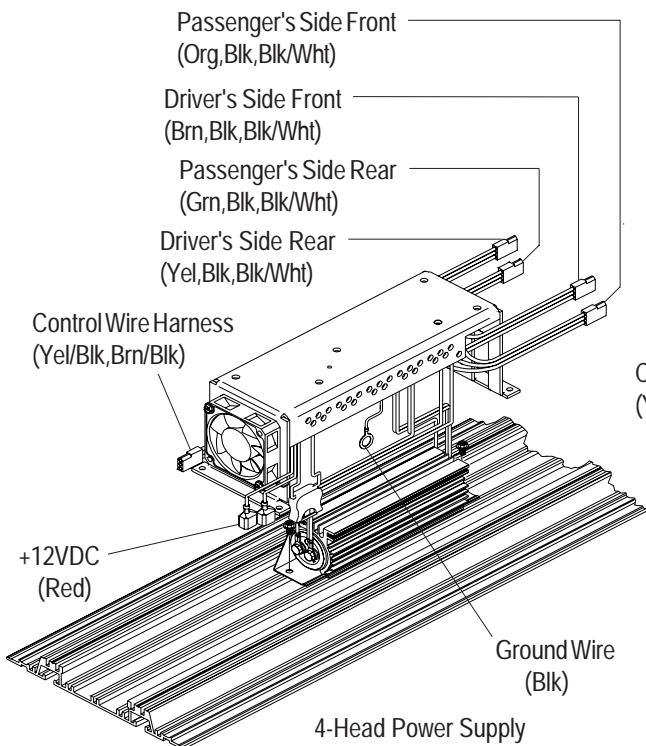

FIGURE 9

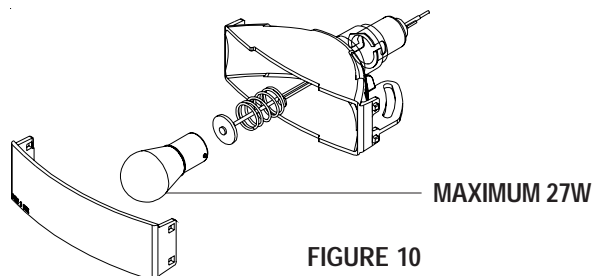
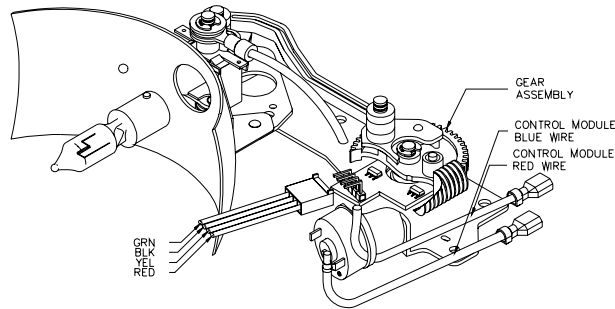

FIGURE 10

**Multi-Functional Intersection Control System** - This system allows multiple lighting options with a single pair of intersection lights. The control center of the system is the Multi-Functional Control Module located in the lower section of the light bar. This combined with the Sensing Lighthouse Assemblies, located in the front lower section, allows the operator to select (4) four modes of operation - intersection, driver side alley, passenger side alley and takedown positions.



WIRE	FUNCTION
GRN	ALLEY
BLK	GROUND
YEL	TAKEDOWN
RED	POWER

**Figure 11**  
**S50690** - Driver side assembly  
**S50691** - Passenger side assembly

**Sensing Lighthouse Assembly** - As with the standard intersection lights, these are high intensity 120 degree oscillating light assemblies. With addition of the Position Sensing module these lights can be placed in the takedown or alley positions. (Figure 11)

**Note:** If the gear assembly is replaced, care must be taken to insure that the flat nylon washer is seated between the gear and the bottom plate to prevent premature wear and failure.

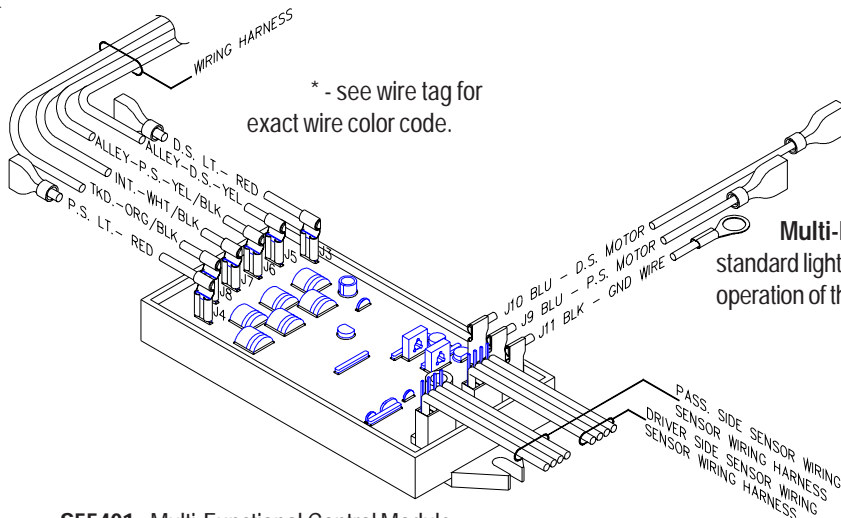

**Multi-Functional Control Module** - Using standard lighting controls the operator can select the operation of the Lighthouse assemblies.

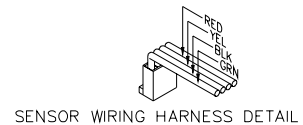

**S55401** - Multi-Functional Control Module

**Figure 12**

**Operation:** The Multi-Functional Intersection Control System will allow the user to obtain Takedown, Intersection and Alley functions with a single pair of intersection modules. The operation is as follows;

**NOTE: Wiring Colors May Vary, Refer To Wire Tag For Exact Colors.**

**Passenger Side Alley** - When the ( YEL/BLK ) wire is connected to a source of +12VDC the passenger's side intersection module will move to the alley position.

**Driver Side Alley** - When the ( YEL ) wire is connected to a source of +12VDC the driver's side intersection module will move to the alley position.

**Intersection** - When the ( WHT/BLK ) wire is connected to a source of +12VDC both intersection modules will oscillate. **When Intersection mode is selected the Passenger side and Driver side Alley mode will be overridden. The user cannot obtain Alley functions while in Intersection mode.**

**Takedown** - When the ( ORG/BLK ) wire is connected to a source of +12VDC both intersection modules will move to the takedown position. **When in Takedown mode, the Alley and Intersection modes are overridden.**

**NOTE: ALL DEVICES USED TO SWITCH +12VDC TO EACH CONTROL WIRE  
MUST BE RATED FOR A MINIMUM OF 10A.**

PROBLEM	POSSIBLE CAUSE	SOLUTION
Lighthouse oscillates when selecting Alley and/or Takedown modes.	Lighthouse not sensing position. Check the following: Bad wiring harness Bad connection Failed position sensor	Replace wiring harness Check connections (Figure 10 & 11) Replace lighthouse assembly
Lighthouse doesn't move when Alley and/or Takedown mode is selected, but moves in Intersection mode	Failed lighthouse assembly	Replace lighthouse assembly
Lighthouse does not move when any mode is selected.	Bad motor wire to module Failed light bar wire harness No power to control module Failed lighthouse assembly Failed control module	Check connections / Replace wire Check light bar wiring harness Check +12VDC switching control Replace lighthouse assembly Replace control module
Lighthouse operates properly, but lamp is not on	Lamp burnt out Bad lamp wire to module	Replace lamp (50W maximum) Check connections / Replace wire
Driver side lighthouse oscillates and Passenger side lighthouse does not move when Takedown is selected. <b>Note:</b> In Takedown mode, Passenger side lighthouse will not move until Driver side lighthouse has located	Driver side lighthouse not sensing Check for the following: Bad wiring harness Bad wiring harness connection Failed position sensor	Replace wiring harness Check connections (Figure 10 & 11) Replace lighthouse assembly
Intersection mode selected, Driver and Passenger side Alley modes do not function	No problem	Normal operation, Intersection mode overrides Alley mode.
Takedown mode selected, no other modes operational	No problem	Normal operation, Takedown mode overrides all other modes

# CODE 360 EXPLODED VIEW

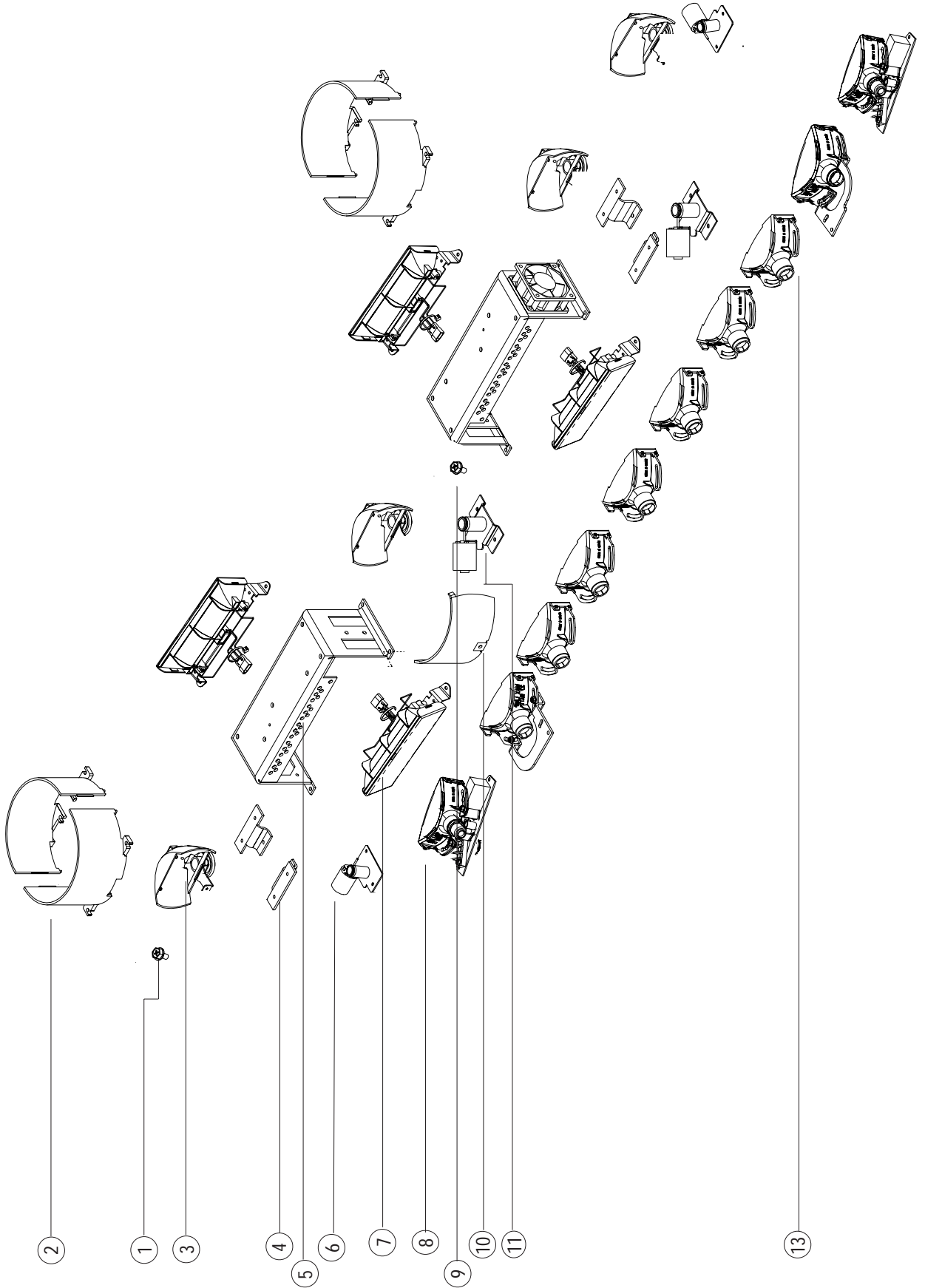

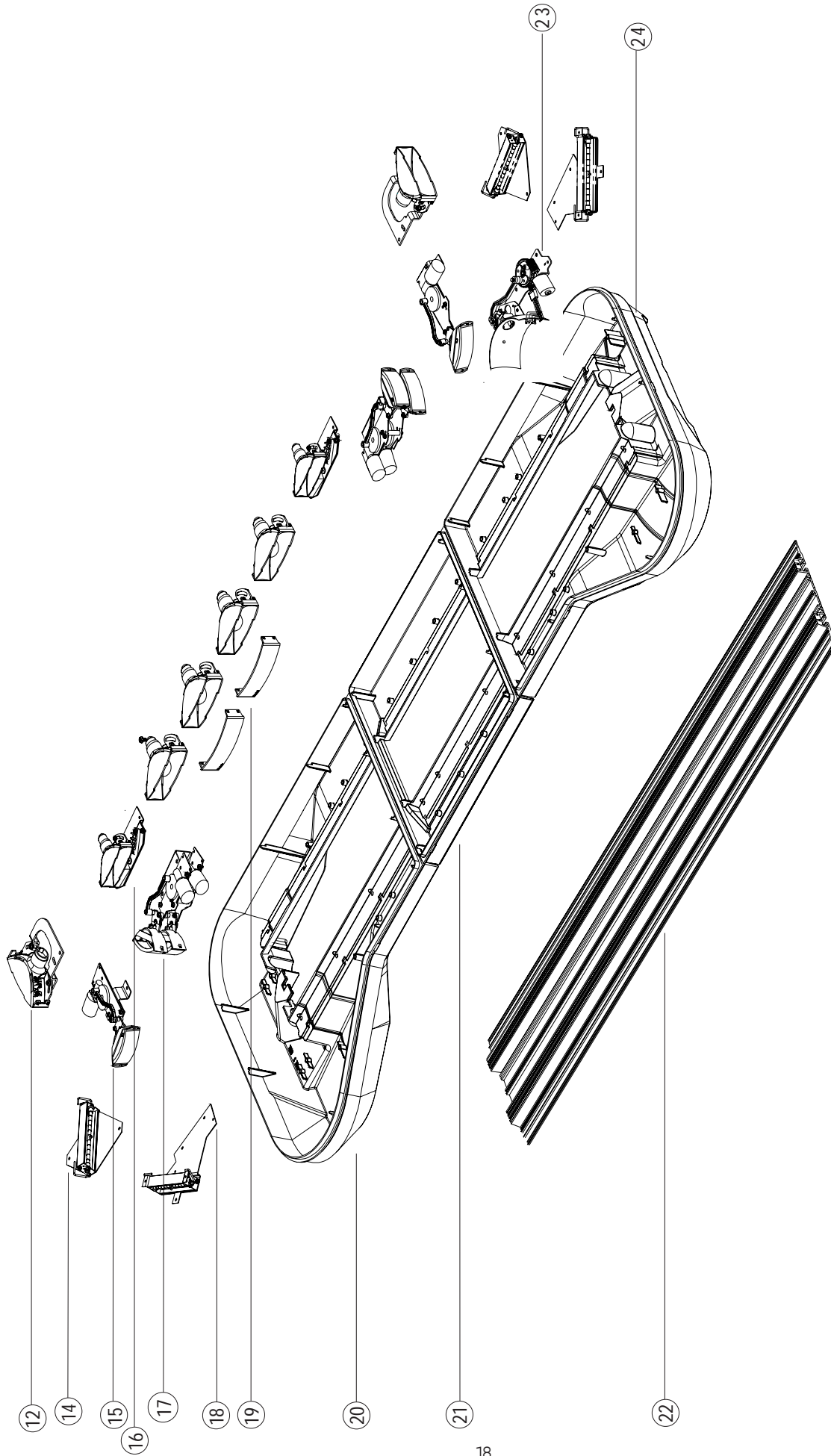

FIGURE 13

## Parts List

(Reference numbers identify items shown in Figures on previous pages)

Ref No.	Description	Part No.	
9	#8 x .250" Sheet Metal Screw		T05029
	#8 x .270" Sheet Metal Screw		T01215
1	#8 x .375" Sheet Metal Screw		T00243
	5/16" Cable Clamp		T00346
	1/2" Cable Clamp		T00903
	3/8" Cable Clamp		T00938
	H-1 Lamp Retaining Clip		T00928
	H-1 55W 12V Halogen Lamp		T01543
	Bayonet 35W 12V Halogen Lamp		T09301
	Bayonet 27W 12V Halogen Lamp		T05093
	Bayonet 20W 12V Halogen Lamp		T05092
	1156 28W 12V Incandescent Lamp		T01538
6&11	Rotator Motor Assy--(Does not include Reflector Assy)		
	Rotator Motor Assy 55W H-1 Std Speed		S95978
	Rotator Motor Assy 55W H-1 Fast Speed		S95979
	Rotator Motor Assy 50W Bayonet Std Speed		S95980
	Rotator Motor Assy 50W Bayonet Fast Speed		S95981
	Rotator Motor Assy 24V		S95982
10	Rotating Filter		
	Green		S95988M
	Red		S95989M
	Blue		S95990M
	Amber		S95991M
2,4	Code 360° 1/2 Cyl. Filter Assy (Front and Rear)		
	Inboard or Center Position		
	Green		S50870M
	Red		S50872M
	Blue		S50873M
	Amber		S50874M
	Black		S50871M
	Outboard Front		
	Green		S81922M
	Red		S81923M
	Blue		S81924M
	Amber		S81925M
	Outboard Rear		
	Green		S13526M
	Red		S13523M
	Blue		S13524M
	Amber		S13525M
	Lens Clip		T01777
	Code 360° Top Outboard Lens DS	Code 360° Top Outboard Lens PS	
	Clear T06841	Clear T06831	
	Red T06842	Red T06832	
	Blue T06843	Blue T06833	
	Amber T06844	Amber T06834	
	Code 360° Top Center Lens		
	Clear		T02131
	Red		T02132
	Blue		T02133
	Amber		T02134
20,24	Code 360° Lower Outboard Lens DS - Clear		S81874M
	Code 360° Lower Outboard Lens PS - Clear		S81875M

21	Code 360® Bottom Center Lens - Clear	S50858M
	Code 360® Full Diamond Mirror	S81887M
	Code 360® 2-Step Cascade Mirror Dr. Front Flash	S50791M
	Code 360® 2-Step Cascade Mirror Pass Front Flash	S50792M
	Code 360® Flat Mirror Dr. Front or Pass Rear Flash	S50787M
	Code 360® Flat Mirror Dr. Rear or Pass Front Flash	S50788M
	Code 360® 104° V-Mirror	S50793M
	Code 360® Multi-function int. module	S81891
15	Code 360® Intersection module	S81929
16	Code 360® Tactical takedown front DS	S81918
	Code 360® Tactical takedown front PS	S81917
8	Code 360® Tactical takedown rear	S81919
17	Code 360® x-sweep int. module DS	S81931M
	Code 360® x-sweep int. module PS	S81930M
	Code 360® 20W Halogen Stationary Module	S50849M
	Code 360® 27W Halogen Stationary Module	S50850M
	Code 360® 28W Incandescent Stationary Module	S50851M
13	Code 360® 28W Incandescent Arrowstik Module	S50848
	Code 360® 20W Halogen Alley Light Driver	S50855
	Code 360® 20W Halogen Alley Light PASS.	S50856
12	Code 360® 27W Halogen Alley Light Driver	S50863
	Code 360® 27W Halogen Alley Light PASS.	S50864
19	Halogen Lower Light Head Filter	
	Green	T05170
	Clear	T05171
	Red	T05179
	Blue	T05173
	Amber	T05174
	Code 360® External D.O.T. Strip Assembly	S50838M
	Code 360® Stop/Turn/Tail Light W/Adapter Plate	S50837M
	Oscilaser Module 35W	S50343M
	Upper Level 50W Halogen Stationary Module	S50839M
5	Strobe 2-Head Power Supply	S80318M
	Strobe 4-Head Power Supply	S80313M
7	Strobe Upper Light Head Assembly – Corner	T09424
	Strobe Up Lt Hd Assy – End Sig Pos Mirror – DS Frt/PS Rr	T09409
	Strobe Up Lt Hd Assy – End Sig Pos Mirror – PS Frt/DS Rr	T09406
	Strobe Upper Light Head Assy – Corner Filter	
	Red	T09442
	Blue	T09443
	Amber	T09444
	Strobe Upper Light Head Assembly – Front/Rear	T09425
	Strobe Upper Light Head Assy – Front/Rear	
	Red	T09432
	Blue	T09433
	Amber	T09434
18	Code 360® corner lower strobe head DS	S81866M
	Code 360® corner lower strobe head PS	S81914M
	Code 360® x-fire strobe module	S81920M
12	Strobe Lower Front/Rear Light Head Assembly	S50888M
	Strobe Lower Light Head Tube Assembly 4"	T03893
	Strobe Lower Light Head Filter	
	Green	S50880M
	Red	S50882M
	Blue	S50883M
	Amber	S50884M
23	Multi-Functional Intersection lighthead DS	S50690M
	Multi-Functional Intersection Lighthead PS	S50691M
3	Rotating Reflector Assembly	S95977

# Troubleshooting

All CODE 360® lightbars are thoroughly tested prior to shipment. However, should you encounter a problem during installation or during the life of the product, follow the guide below for information on repair and troubleshooting. Additional information may be obtained from the factory technical help line at 314-426-2700 ext. 2131.

**NO STROBE LIGHTS IN THE LIGHTBAR OPERATE** - Check the following: 1) +12 VDC source connection for the control switch box and any in line fuse 2) Connection of the RED and RED/BLK or RED/WHT wire at the control switch box 3) Check the 15 Amp ATO fuse on each power supply. If the fuse is blown, replace it with another **15 Amp fuse** and test the lightbar. If the fuse continues to blow, return the power supply only, NOT the entire lightbar, to the factory for service. For instructions on power supply removal see the " Electronics Module Removal " section of this manual.



**WARNING!** Do not replace the fuse with one of a higher rating. This will damage the power supply and void all warranties.

**ONE STROBE LIGHT MODULE DOES NOT OPERATE** - Check the defective strobe light module by switching it with a module that is known to be working.

## STROBE OPTION TROUBLESHOOTING GUIDE

PROBLEM	CAUSE	SOLUTION
Light heads do not fire.	<ul style="list-style-type: none"> <li>a. Harness that connects power supply to strobe head has loose connections or damaged harness.</li> <li>b. Faulty strobe Lighthouse.</li> <li>c. High voltage shorting to ground (earth) through harness.</li> </ul>	<ul style="list-style-type: none"> <li>a. Check all connections. Check harness by switching harness with functioning strobe head. Replace harness.</li> <li>b. Check with known good lighthouse.</li> <li>c. Isolate shorted harness by disconnecting one at a time. Replace harness.</li> </ul>
Only front strobes flash.	<ul style="list-style-type: none"> <li>a. GREEN/BLACK control wire connected to +12VDC overrides other modes.</li> </ul>	<ul style="list-style-type: none"> <li>a. See "Strobe Lighting Connections" section. Reconnect switching.</li> </ul>
No DIM	<ul style="list-style-type: none"> <li>a. Module White wire not connected to source of +12V</li> </ul>	<ul style="list-style-type: none"> <li>a. Connect White wire to a switched source of +12V</li> </ul>

Follow the guide below for information on repair and trouble shooting for the arrowstik option.

**ARROWSTIK OPTION  
TROUBLESHOOTING GUIDE**

PROBLEM	QUESTION	CAUSE	SOLUTION
ArrowStik® does not function when turned on	Are LED's functioning properly?  Yes  No	 a. Plug in rear of control box is loose or disconnected. b. Poor ground connection a. Power from battery has been disconnected or the control box has been damaged.	 a. Reconnect plug. b. Reconnect ground. a. Check connections at the battery and plug. If connections are good and voltage is at least 10 volts, the control box has been damaged. Repair or return to Code 3®.
Lamp does not come on when it should.	Are LED's functioning properly?  Yes  No	 a. Lamp has burned out. b. Bad wiring connection.  a. Control box has been damaged.	 a. Replace lamp. b. Repair connection.  a. Repair or return to Code 3.
Right most lamp does not come on in Arrow Left mode or left most lamp does not come on in Arrow Right mode.		a. Normal operation	a. None
ArrowStik runs opposite pattern than selected.		a. Defective Wiring.  b. Control box has been damaged.	a. Check that the cable exit is on the driver's side b. Repair or return to Code 3. a. Repair or return to Code 3.
Lamp looks dim.		a. Defective lamp. b. Low voltage. c. Poor ground d. Product is in "Dim" mode.	a. Replace lamp. b. Check connections or battery. c. Check ground and wire gauge. d. Select appropriate mode.

**NOTES:**

## NOTES:

# WARRANTY

Code 3<sup>®</sup>, Inc.'s emergency devices are tested and found to be operational at the time of manufacture. Provided they are installed and operated in accordance with manufacturer's recommendations, Code 3<sup>®</sup>, Inc. guarantees all parts and components except the lamps to a period of 1 year (unless otherwise expressed) from the date of purchase or delivery, whichever is later. Units demonstrated to be defective within the warranty period will be repaired or replaced at a factory service center at no cost.

Use of lamp or other electrical load of a wattage higher than installed or recommended by the factory, or use of inappropriate or inadequate wiring or circuit protection causes this warranty to become void. Failure or destruction of the product resulting from abuse or unusual use and/or accidents is not covered by this warranty. Code 3<sup>®</sup>, Inc. shall in no way be liable for other damages including consequential, indirect or special damages whether loss is due to negligence or breach of warranty.

**CODE 3<sup>®</sup>, INC. MAKES NO OTHER EXPRESS OR IMPLIED WARRANTY INCLUDING, WITHOUT LIMITATION, WARRANTIES OF FITNESS OR MERCHANTABILITY, WITH RESPECT TO THIS PRODUCT.**

# PRODUCT RETURNS

If a product must be returned for repair or replacement\*, please contact our factory to obtain a Return Goods Authorization Number (RGA number) before you ship the product to Code 3<sup>®</sup>, Inc. Write the RGA number clearly on the package near the mailing label. Be sure you use sufficient packing materials to avoid damage to the product being returned while in transit.

\*Code 3<sup>®</sup>, Inc. reserves the right to repair or replace at its discretion and assumes no responsibility or liability for expenses incurred for the removal and /or reinstallation of products requiring service and/or repair.; nor for the packaging, handling, and shipping; nor for the handling of products return to sender after the service has been rendered.

Code 3<sup>®</sup>, Inc., a subsidiary of  
Public Safety Equipment, Inc.

**CODE 3**  
PUBLIC SAFETY EQUIPMENT, INC.

Code 3<sup>®</sup>, Inc.  
10986 N. Warson Road  
St. Louis, Missouri 63114-2029—USA  
Ph. (314) 426-2700 Fax (314) 426-1337  
[www.code3pse.com](http://www.code3pse.com)

Revision 8, 7/05 - Instruction Book Part No. T07514  
©2005 Code 3, Inc. Printed in USA